



Steam Injection Humidifiers

PURE Humidifier Company steam injection humidifiers are “job-engineered” to assure highly efficient steam release into the air stream. Each humidifier is designed for your specific capacity, steam pressure, and duct size requirements. Single and multiple injection tube units are available to meet the most demanding applications.

High quality control valves and actuators assure accurate response and metering of steam flow. If you prefer to use your own valves and actuators, we will factory mount them for you. Or, if you have a preference for certain valve/actuator combinations, we can usually supply them with the humidifier. Just another way we “job-engineer” the humidifiers to meet your needs.

Only high quality corrosion resistant stainless steel is used in the construction of the separator and injection tube.

Steam jacketing around the inner tubes means any condensate is “flashed off”. Only *PURE* steam is delivered, free of water or particulate matter.

Our unique round injection tube requires 80% less welding than rectangular designs and provides 100% steam jacketing of the inner tube. This design creates a stronger and more aerodynamic tube with less metal fatigue and improved air-to-steam characteristics. The increased steam jacketing area provides a hotter tube which delivers *PURE* steam free of condensate.

All PURE Humidifier Company steam injection humidifiers are equipped with our patented centrifugal steam separator (patent no. 4,509,965). This light weight stainless steel separator completely removes all condensate from the humidification system and provides instantaneous warm-up.

A variety of piping options gives you the flexibility of installing the PURE Humidifier Company steam injection humidifier in confined spaces.

The versatility of our steam injection humidifier will allow you to design them into any system simply, efficiently, and reliably.

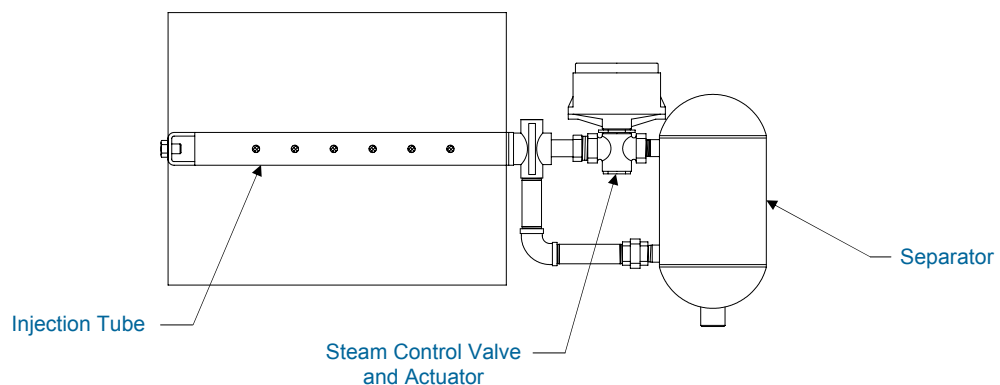

Our results are comforting



All PURE Humidifier Co. steam injection humidifiers are designed with a steam jacketed injection tube(s) and a patented centrifugal steam separator (patent no. 4,509,965). Used in combination with each other, these components ensure the delivery of condensate free, *PURE* steam, into the air stream.

Single Tube, Multiple Tube, Mini-Mult, and Area Type humidifiers all operate with the same basic design. However, the steam path is slightly different in the Single Tube and Area Type humidifiers versus the Multiple Tube and Mini-Mult humidifier.

Figure A—Single Tube

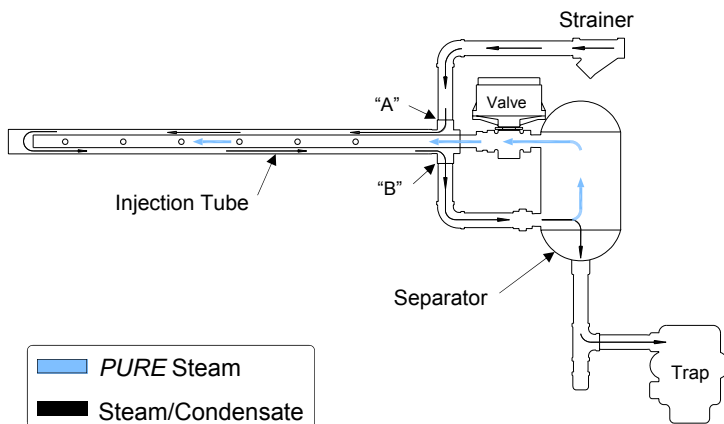

Figure B—Multiple Tube

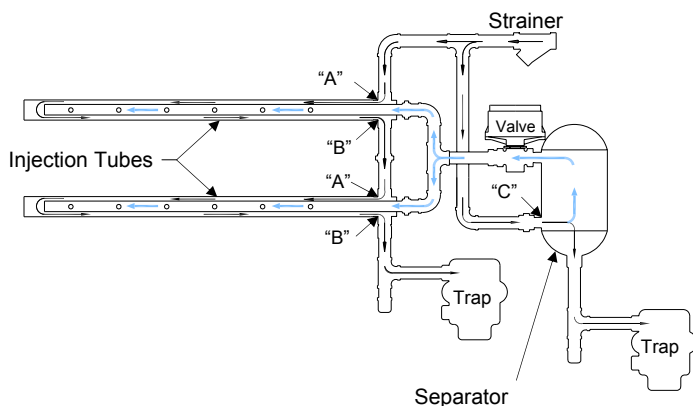
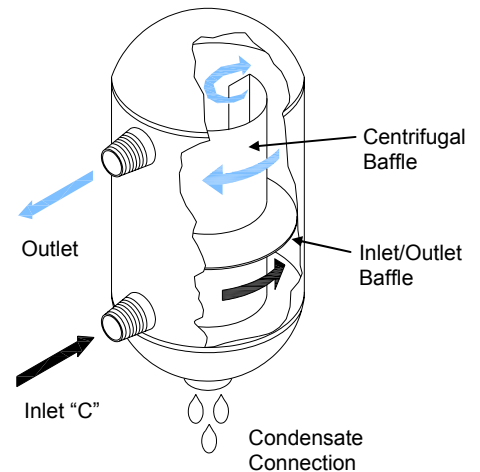

Figure C



In the Single Tube and Area Type humidifiers, the steam enters the humidifier through the strainer and travels into the injection tube outer jacket at connection "A" (reference Fig. A). The steam then continues to circulate around the outer jacket of the injection tube and leaves the tube jacket at outlet "B". The steam then travels through the interconnecting piping to the inlet of the steam separator (connection "C").

Inside the separator, the combination of steam and condensate is directed into a circular flow by the internal baffle (reference Fig. C). The condensate, being heavier than the steam, is forced to the outside wall by the centrifugal force created within the separator and is removed from the system by a steam trap. The *PURE* steam, free of condensate, then rises past the inlet/outlet baffle and flows out of the separator to the control valve (reference Fig. C).

On a call for humidity the control valve opens and allows the proper quantity of *PURE* steam to flow into the jacketed inner tube and thus be emitted out of the injection tube into the air stream (reference Fig. A).

In the case of Multiple Tube and Mini-Mult humidifiers, the only variation is that, after the strainer, the steam supply is piped directly to the inlet of the separator (reference Fig. B). An auxiliary steam supply is piped to the first injection tube to provide the steam jacketing. The auxiliary steam supply circulates around the injection tubes and is independently trapped (reference Fig. B). The injection tubes are piped and trapped separately to ensure that the additional resistance created by the extra piping does not reduce the steam supply to the humidifier. This also provides extra trap capacity to handle the additional condensate created within the multiple injection tube steam jackets.



Single Tube Humidifier Selection

Single injection tube humidifiers from PURE Humidifier Company are factory piped and assembled (after piping at the factory, units over four feet (10.2 cm) in length are disassembled at the unions for ease of shipping).

To properly select a single tube humidifier:

1. Select the correct model from Table 1 by referencing the steam supply pressure and humidification load required in lbs/hr.
2. Add the required valve actuator prefix and injection tube insertion length suffix to the model number (reference "Model Nomenclature")

Example Total humidification load = 76lbs/hr @ 10 psig
 Number of injection tubes required = 1
 Duct width = 5 ft (12.7 cm); Pneumatic valve required

From Table 1 you will see that a Model 50-10 is required. Adding the proper prefix and suffix;

The correct model number would be: **P50-10-5'-1**

Example:

P50 - 10 - 2' - 1

- Quantity of Injection Tubes
- Tube Length (in feet)
- Tube Model Number
- Separator Model Number
- Type of Valve Control;
- P = Pneumatic
- M = Electric Modulating
- E = Electric On-Off

NOTES:

1. All dashed line piping is by others.
2. † = PURE Humidifier Company.
3. Reference page SI-4 for Single Tube model dimensions and weights.

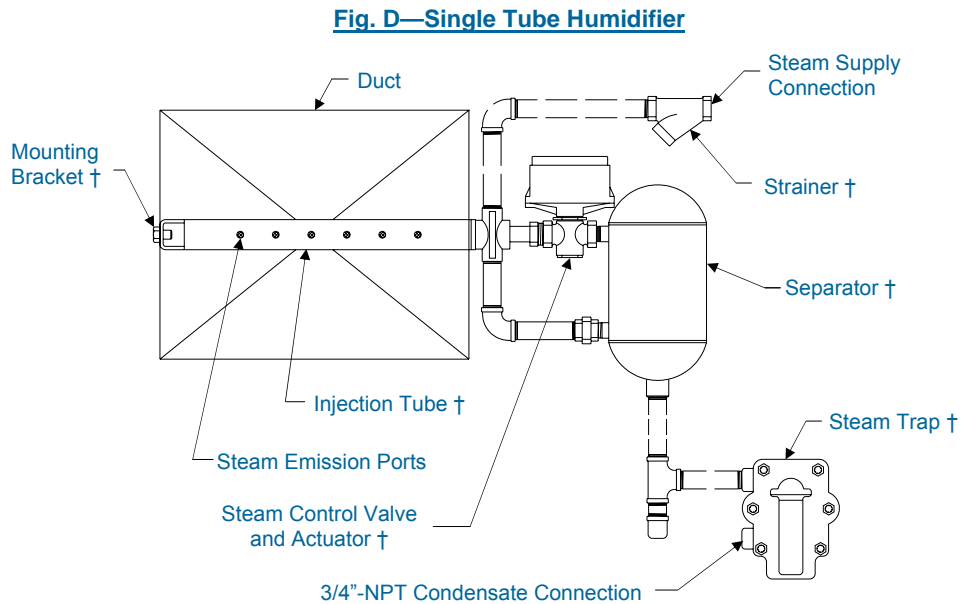

Table 1 Single Injection Tube Humidifier Stream Capacity in pounds per hour (lbs/hr)

Model Number	Valve Cv (Size-NPT)	Steam Pressure to Humidifier Supply Connection in psig																						
		2	3	4	5	6	7	8	9	10	11	12	13	14	15	20	25	30	35	40	45	50	55	60
50-10	.10 (1/2")	1.6	1.9	2.3	2.6	2.8	3.0	3.2	3.4	3.6	3.8	4.0	4.2	4.3	4.4	5.1	5.7	6.3	6.8	7.3	7.7	8.1	8.5	8.9
	.22 (1/2")	3.5	4.2	5.0	5.6	6.5	6.6	7.1	7.6	8	8	9	9	10	10	11	13	14	15	16	17	18	19	20
	.40 (1/2")	6.4	7.6	9.1	10	11	12	13	14	15	15	16	16	17	18	20	23	25	27	29	31	33	34	36
	.75 (1/2")	12	14	17	19	21	23	24	26	27	28	30	31	32	33	38	43	47	50	54	57	60	63	66
	.95 (1/2")	15	18	21	24	27	29	31	33	34	36	38	39	40	42	48	54	59	64	68	72	76	80	84
	1.30 (1/2")	21	24	29	33	36	39	42	44	47	49	51	53	55	57	66	74	80	87	93	99	104	109	114
	1.75 (1/2")	28	33	40	44	49	52	56	60	63	66	69	72	74	76	88	99	107	116	124	132	139	146	153
	2.20 (1/2")	35	41	50	55	61	66	71	75	79	82	86	90	93	95	111	123	134	146	156	165	174	183	192
	2.80 (1/2")	45	53	64	70	78	84	90	96	100	104	109	114	118	121	141	157	171	186	199	210	221	233	244
3.25 (1/2")	52	61	73	82	90	96	104	110	116	121	127	132	137	140	163	181	198	214	229	244	257	270	282	
4.40 (1/2")	70	83	98	110	121	130	141	149	157	163	172	178	185	190	221	244	266	290	310	328	345	363	381	
60-20	5.50 (3/4")	85	104	123	138	150	161	176	186	196	204	213	222	231	236	275	305	333	360	385	408	430	451	471
	6.20 (3/4")	96	117	138	155	169	182	198	210	220	230	240	250	259	265	310	343	372	403	434	459	485	508	529
	7.50 (3/4")	116	142	166	186	204	220	238	253	265	277	289	302	312	320	373	412	450	487	525	555	585	614	640
70-20	8.20 (1")	123	155	180	204	223	240	261	275	290	303	313	328	341	349	407	443	488	529	570	603	635	668	703
	10.0 (1")	150	189	220	248	272	293	317	335	354	370	380	400	414	423	497	540	595	645	695	735	770	810	850
	12.0 (1")	180	228	264	296	326	351	378	402	422	441	456	465	492	505	595	648	714	774	828	876	Δ	Δ	Δ
80-30	20.0 (1-1/4")	300	375	440	494	540	582	630	666	702	736	750	772	814	834	990	1060	1180	1280	1376	1460	Δ	Δ	Δ
	28.0 (1-1/2")	420	511	612	686	756	812	873	927	980	1024	1044	1075	1128	1165	1383	1484	1638	1778	1912	2044	Δ	Δ	Δ



Table 2 Single Injection Tube Humidifier Dimensions in inches (cm)

Model Number	Dim "A"	Dim "B"	Dim "C"	Dim "D"†	Dim "E"	Dim "F"†	Dim "G"	Strainer Size
50-10	4.5" (11.4)	1.5" (3.8)	3.0" (7.6)	12.0" (30.5)	8.5" (21.6)	13.25" (33.7)	1/2"-NPT	1/2"-NPT
60-20	5.5" (14.0)	2.0" (5.1)	3.5" (8.9)	14.375" (36.5)	9.25" (23.5)	14.75" (37.5)	3/4"-NPT	3/4"-NPT
70-20	6.5" (16.5)	2.0" (5.1)	3.5" (8.9)	16.375" (41.6)	10.25" (26.0)	16.25" (41.3)	3/4"-NPT	3/4"-NPT
80-30	7.5" (19.1)	3.0" (7.6)	4.75" (12.1)	19.0" (48.3)	11.75" (29.9)	21.5" (54.6)	1-1/4"-NPT	1-1/4"-NPT

† Valve manufacturer, Cv, and actuator type will affect this dimension. The dimensions shown are based on an Invensys valve and pneumatic actuator.

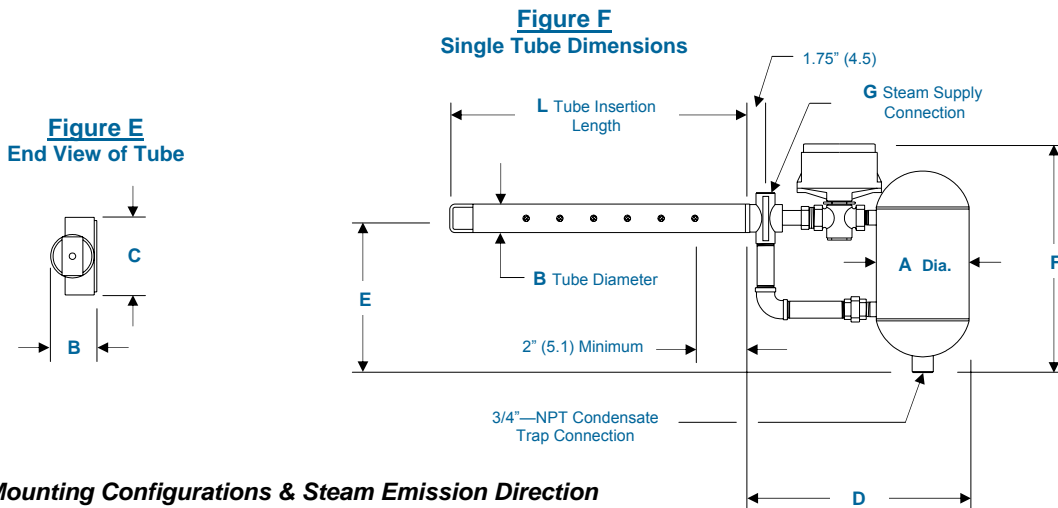
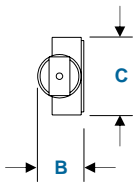

Figure E
End View of Tube



Mounting Configurations & Steam Emission Direction

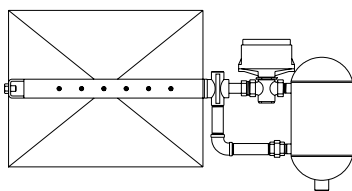

Figure 1
Horizontal Air Flow

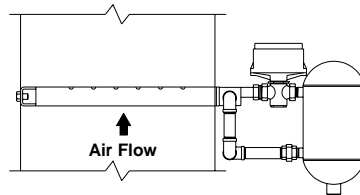

Figure 2
Vertical Air Flow

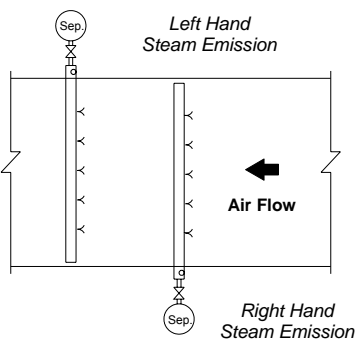

Figure G— Plan View
(Horizontal Duct)

Steam Emission Direction

Steam emission should be into the air flow, except when an optional insulated injection tube is utilized (in which case the steam should emit with the air flow).

On vertical air flow applications, the steam should emit upward, regardless of the air flow direction.

Tube piping direction (right or left hand emission) can be determined by referencing the Plan View (Horizontal Duct) drawing (Fig. G).

Table 3 Insertion Lengths & Unit Weights

Dim "L"†† Insertion Length in inches (cm)	Unit Weight by Model Number in pounds (kg) ΔΔ			
	50-10	60-20	70-20	80-30
6" (15.2)	18.5 (8.4)	Δ	Δ	Δ
12" (30.5)	19.0 (8.6)	21.5 (9.8)	25.0 (11.4)	Δ
18" (45.7)	19.5 (8.9)	22.0 (10.0)	25.5 (11.6)	Δ
24" (61.0)	20.0 (9.1)	22.5 (10.2)	26.0 (11.8)	Δ
30" (76.2)	20.5 (9.3)	23.0 (10.4)	26.5 (12.0)	Δ
36" (91.4)	21 (9.5)	23.5 (10.7)	27 (12.3)	43.5 (19.7)
48" (121.9)	22 (10.0)	24.5 (11.1)	28 (12.7)	45.0 (20.4)
60" (152.4)	23 (10.4)	25.5 (11.6)	29 (13.2)	46.5 (21.1)
72" (182.9)	24 (10.9)	26.5 (12.0)	30 (13.6)	48.0 (21.8)
84" (213.4)	25 (11.4)	27.5 (12.5)	31 (14.1)	49.5 (22.5)
96" (243.8)	26 (11.8)	28.5 (12.9)	32 (14.5)	51.0 (23.2)
108" (274.3)	27 (12.3)	29.5 (13.4)	33 (15.0)	52.5 (23.8)
120" (304.8)	28 (12.7)	30.5 (13.9)	34 (15.4)	54.0 (24.5)
132" (335.3)	29 (13.2)	31.5 (14.3)	35 (15.9)	55.5 (25.2)
144" (365.8)	30 (13.6)	32.5 (14.8)	36 (16.3)	57.0 (25.9)
156" (396.2)	Δ	33.5 (15.2)	37 (16.8)	58.5 (26.6)
168" (426.7)	Δ	34.5 (15.7)	38 (17.3)	60.0 (27.2)

†† Standard insertion lengths. Special tube lengths are available; consult the factory for details.
 Δ Indicates a special order item; consult factory for details.
 ΔΔ The weights shown include the separator, injection tube, valve, pneumatic actuator, strainer, and F & T trap.



Multiple Tube Humidifier Selection

Multiple injection tube humidifiers from PURE Humidifier Company include all the features of the single tube units. However, the separator/valve assembly and injection tubes are ordered separately to match the correct capacity for both the separator/valve assembly and the injection tubes.

To properly select a multiple tube humidifier:

1. Select the correct separator/valve assembly from Table 4 by referencing the steam supply pressure and humidification load required in lbs/hr.
2. Select the proper injection tube model from Table 5 by referencing the steam supply pressure and humidification load required per injection tube (total load ÷ qty. of tubes desired). Reference the "Recommended Quantity of Injection Tubes" section on this page to assist in determining the quantity of injection tubes required.

Example Total humidification load = 383 lbs/hr @ 10 psig
 Number of injection tubes required = 2
 Injection tube humidification capacity = 191.5
 Duct width = 60" (5'); Pneumatic valve required.

From Table 4 you will see that a Model 70 Separator/Valve assembly is required. From Table 5 you will see that a model 10 injection tube, at 10 psig can emit the required tube humidification load.

The correct model number would be: **P70-10-5'-2**

Recommended Quantity of Injection Tubes

When steam is emitted from the injection tube, it immediately condenses into tiny water droplets. As the steam (fog) travels downstream, the air slowly absorbs the condensed steam until all the water droplets have changed state back to a gas; this distance is called dissipation distance.

In many installations a single injection tube will provide the dissipation distance required. However, there are applications where the conditions necessitate the use of multiple injection tubes to achieve a shorter dissipation distance.

To prevent condensation on in-duct objects, such as dampers, coils, filters, or turning vanes, it is very important that the dissipation distance be shorter than the distance from the humidifier to the in-duct object. The following recommendations should be used when designing a multiple injection tube system:

Duct Height	Recommended Qty. of Tubes †
Up to 36"	2
37" - 48"	3
49" - 72"	4
73" - 96"	5
Above 96"	6

† Final duct relative humidity air velocity and available dissipation distance will affect the quantity of tubes required.

Table 4 Multiple Tube Humidifier Separator / Valve Steam Capacity in pounds per hour (lbs/hr)

Model Number	Valve Cv (Size-NPT)	Steam Pressure to Humidifier Supply Connection in psig																						
		2	3	4	5	6	7	8	9	10	11	12	13	14	15	20	25	30	35	40	45	50	55	60
50	.10 (1/2")	1.6	1.9	2.3	2.6	2.8	3.0	3.2	3.4	3.6	3.8	4.0	4.2	4.3	4.4	5.1	5.7	6.3	6.8	7.3	7.7	8.1	8.5	8.9
	.22 (1/2")	3.5	4.2	5.0	5.6	6.5	6.6	7.1	7.6	8	8	9	9	10	10	11	13	14	15	16	17	18	19	20
	.40 (1/2")	6.4	7.6	9.1	10	11	12	13	14	15	15	16	16	17	18	20	23	25	27	29	31	33	34	36
	.75 (1/2")	12	14	17	19	21	23	24	26	27	28	30	31	32	33	38	43	47	50	54	57	60	63	66
	.95 (1/2")	15	18	21	24	27	29	31	33	34	36	38	39	40	42	48	54	59	64	68	72	76	80	84
	1.30 (1/2")	21	24	29	33	36	39	42	44	47	49	51	53	55	57	66	74	80	87	93	99	104	109	114
	1.75 (1/2")	28	33	40	44	49	52	56	60	63	66	69	72	74	76	88	99	107	116	124	132	139	146	153
	2.20 (1/2")	35	41	50	55	61	66	71	75	79	82	86	90	93	95	111	123	134	146	156	165	174	183	192
	2.80 (1/2")	45	53	64	70	78	84	90	96	100	104	109	114	118	121	141	157	171	186	199	210	221	233	244
3.25 (1/2")	52	61	73	82	90	96	104	110	116	121	127	132	137	140	163	181	198	214	229	244	257	270	282	
4.40 (1/2")	70	83	98	110	121	130	141	149	157	163	172	178	185	190	221	244	266	290	310	328	345	363	381	
60	5.50 (3/4")	85	104	123	138	150	161	176	186	196	204	213	222	231	236	275	305	333	360	385	408	430	451	471
	6.20 (3/4")	96	117	138	155	169	182	198	210	220	230	240	250	259	265	310	343	372	403	434	459	485	508	529
	7.50 (3/4")	116	142	166	186	204	220	238	253	265	277	289	302	312	320	373	412	450	487	525	555	585	614	640
70	8.20 (1")	123	155	180	204	223	240	261	275	290	303	313	328	341	349	407	443	488	529	570	603	635	668	703
	10.0 (1")	150	189	220	248	272	293	317	335	354	370	380	400	414	423	497	540	595	645	695	735	770	810	850
	12.0 (1")	180	228	264	296	326	351	378	402	422	441	456	465	492	505	595	648	714	774	828	876	Δ	Δ	Δ
80	20.0 (1-1/4")	300	375	440	494	540	582	630	666	702	736	750	772	814	834	990	1060	1180	1280	1376	1460	Δ	Δ	Δ
	28.0 (1-1/2")	420	511	612	686	756	812	873	927	980	1024	1044	1075	1128	1165	1383	1484	1638	1778	1912	2044	Δ	Δ	Δ
90	40.0 (2")	600	720	872	980	1080	1112	1240	1316	1392	1456	1480	1528	1592	1656	1964	2080	2320	2520	2720	2904	Δ	Δ	Δ

Table 5 Injection Tube Steam Capacity per tube in pounds per hour (lbs/hr)

Model Number	Steam Pressure to Humidifier Supply Connection in psig																						
	2	3	4	5	6	7	8	9	10	11	12	13	14	15	20	25	30	35	40	45	50	55	60
10	95	115	134	153	167	181	195	209	225	238	251	263	276	289	302	315	328	341	354	367	380	393	406
20	184	222	266	309	340	371	402	433	463	491	519	546	574	602	630	658	686	714	742	770	798	826	854
30	333	416	489	575	661	681	734	787	840	893	946	999	1052	1105	1158	1211	1264	1317	1370	1423	1476	1529	1582

Metric Conversion: lbs/hr x .4536 = kg/hr 1 psig x 6.895 = Kpa
 Δ Special valve/actuator required; consult factory



Table 6 Separator/Valve Assembly Dimensions & Weights (Ref. Fig. I)

Model Number	Dim "A"	Dim "B"†	Dim "C"†	Dim "D"	Dim "E"	Dim "F"	Strainer Size	Weight in lbs (kg)
50	4.5" (11.4)	13.25" (33.7)	8.75" (22.2)	5.50" (14.0)	1/2"-NPT	1/2"-NPT	1/2"-NPT	18 (8.2)
60	5.5" (14.0)	4.75" (37.5)	10.75" (27.3)	5.75" (14.6)	3/4"-NPT	3/4"-NPT	3/4"-NPT	20 (9.1)
70	6.5" (16.5)	16.25" (41.3)	12.75" (32.4)	6.50" (16.5)	1"-NPT	1"-NPT	1"-NPT	24 (10.9)
80	7.5" (19.1)	21.5" (54.6)	15.50" (39.4)	7.25" (18.4)	1-1/2"-NPT	1-1/2"-NPT	1-1/2"-NPT	38 (17.3)
90	8.5" (21.6)	23.25" (59.0)	16.50" (41.9)	7.50" (19.1)	2"-NPT	2"-NPT	2"-NPT	47 (21.3)

† Valve manufacturer, Cv and actuator type will affect this dimension. The dimensions are shown based on an Invensys valve and pneumatic actuator. The weights shown include: separator, valve, valve actuator, strainer, and two steam traps.

Fig. H—Injection Tube

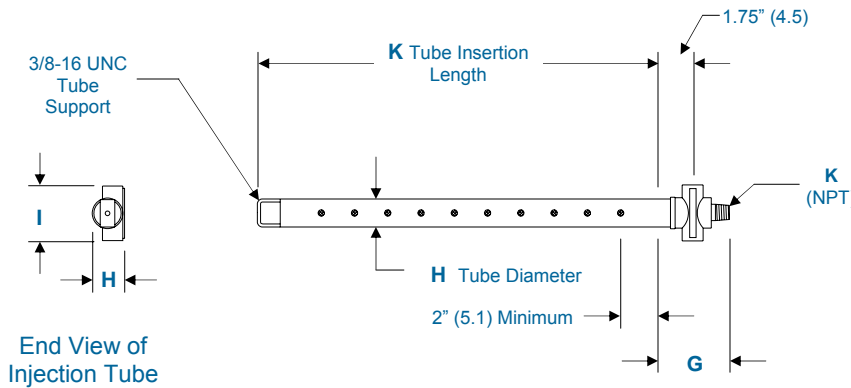

Fig. I—Separator/Valve Assembly

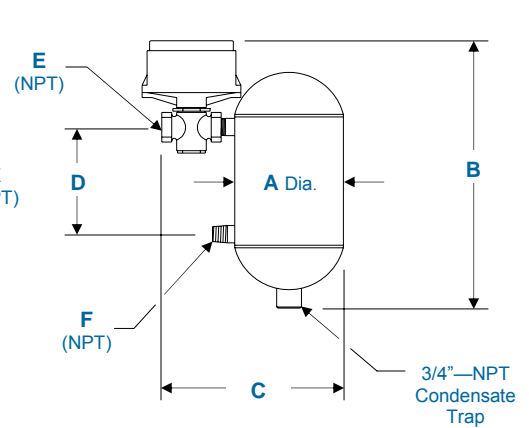

Table 7 Injection Tube Dimensions (Ref. Fig. H)

Model Number	Dim "G"	Dim "H"	Dim "I"	Dim "J"
10	4.50" (11.4)	1.5" (3.8)	3.00" (7.6)	1/2"-NPT
20	4.75" (12.1)	2.0" (5.1)	3.50" (8.9)	3/4"-NPT
30	5.50" (14.0)	3.0" (7.6)	4.75" (12.1)	1-1/4"-NPT

Table 8 Insertion Lengths & Unit Weights

Dim "K"†† Insertion Length in inches (cm)	Unit Weight by Model Number in pounds (kg) Δ		
	10	20	30
6" (15.2)	.5 (.23)	Δ	Δ
12" (30.5)	1.0 (.45)	1.5 (.68)	Δ
18" (45.7)	1.5 (.68)	2.0 (.91)	Δ
24" (61.0)	2.0 (.91)	2.5 (1.1)	Δ
30" (76.2)	2.5 (1.1)	3.0 (1.4)	Δ
36" (91.4)	3.0 (1.4)	3.5 (1.6)	6.0 (2.7)
48" (121.9)	4.0 (1.8)	4.5 (2.0)	7.5 (3.4)
60" (152.4)	5.0 (2.3)	5.5 (2.5)	9.0 (4.1)
72" (182.9)	6.0 (2.7)	6.5 (3.0)	10.5 (4.8)
84" (213.4)	7.0 (3.2)	7.5 (3.4)	12 (5.5)
96" (243.8)	8.0 (3.6)	8.5 (3.9)	13.5 (6.1)
108" (274.3)	9.0 (4.1)	9.5 (4.3)	15.0 (6.8)
120" (304.8)	10 (4.5)	10.5 (4.8)	16.5 (7.5)
132" (335.3)	11 (5.0)	11.5 (5.2)	18.0 (8.2)
144" (365.8)	12 (5.5)	12.5 (5.7)	19.5 (8.9)
156" (396.2)	Δ	13.5 (6.1)	21.0 (9.5)
168" (426.7)	Δ	14.5 (6.6)	22.5 (10.2)

Fig. J — Piping Diagram

Reference piping notes located in the lower right corner of this page.

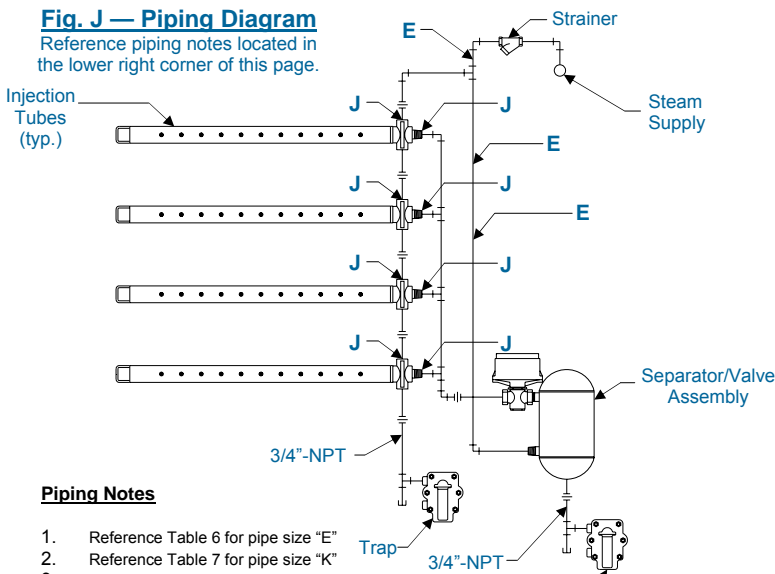

Piping Notes

1. Reference Table 6 for pipe size "E"
2. Reference Table 7 for pipe size "K"
3. **ALL LINE PIPING IS BY OTHERS.** Multiple injection tube humidifiers require field assembly/piping. If factory assembly/piping is required, consult the factory for the optional "Factory Assembled Multiple" (FAM)

†† Standard insertion lengths. Special tube lengths are available; consult the factory for details.

Δ Indicates a special order item; consult factory for details. Reference Fig. H for description of dimension "K"



Mini-Mult Humidifiers

The Mini-Mult humidifier from PURE Humidifier Company includes all of the features of the single tube units. However, the Mini-Mult humidifier is designed for applications that require small humidification loads in a small duct size.

They are ideally suited for any high humidity job where fast steam dissipation in cool air, in a short-run duct, is essential. That means hospital delivery rooms, the O.R., the I.C.U., or "clean rooms" in any high tech application.

The humidifiers are shipped completely assembled and ready for installation. They fit into a slot cut into the duct wall, and the slot is sealed with a factory duct plate.

Specially designed low capacity valve Cv's assure precise humidity control without over-humidification, valve "hunting", or saturation. A complete line of pneumatic, electric modulating, and electric on-off controlled valve actuators are available.

Fig. K—Mini-Mult Side View

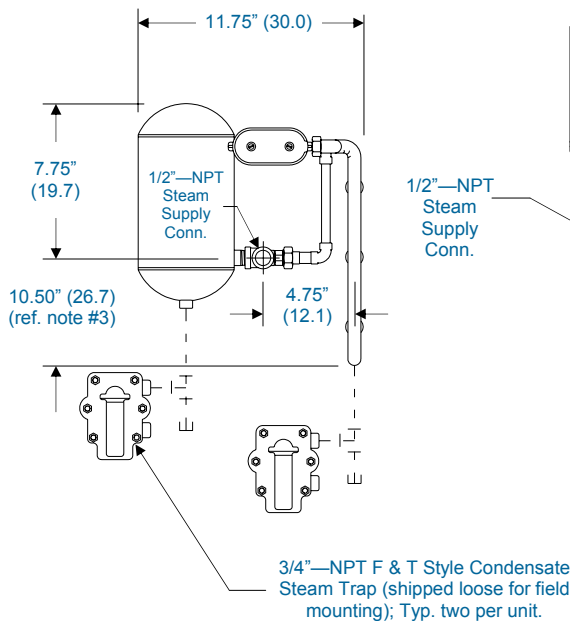

Fig. L—Mini-Mult Front View

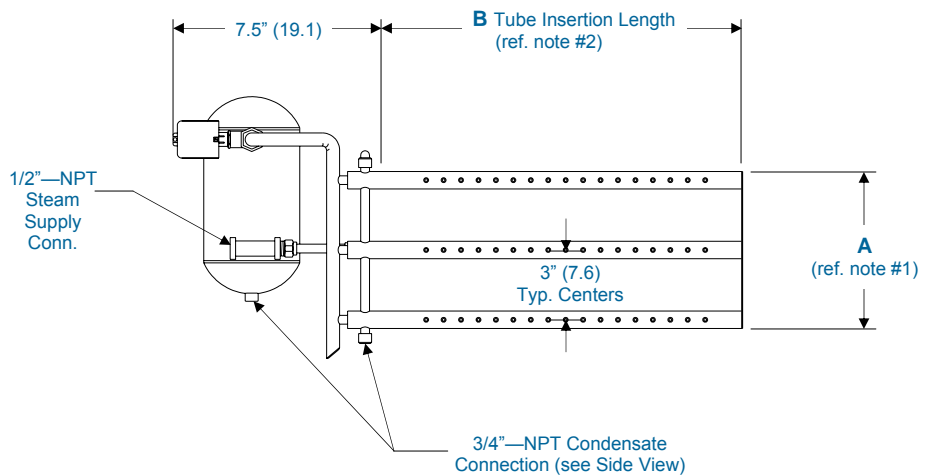
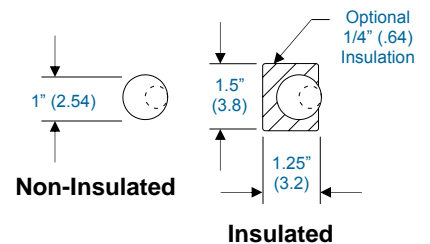

Fig. M—Injection Tube



Notes

1. Dim "A" varies between 4" (10.2 cm) for two tubes and 16" (40.6 cm) for six tubes; varies in 3" (7.6 cm) increments.
2. Dim "B" varies between 6" (15.2 cm) and 48" (122.0 cm) in 2" (5.1 cm) increments, depending upon the insertion length. Reference Table 10 for standard insertion lengths.
3. The overall height increases in 3" increments for each additional injection tube. Reference Table 10 for the recommended quantity of injection tubes.
4. All dimensions are in inches (cm); all dimensions are for reference only.
5. Dotted line piping is by others.

Table 9 Mini-Mult Humidifier Steam Capacity in pounds per hour (lbs/hr)

Model Number	Valve Cv (Size-NPT)	Steam Pressure to Humidifier Supply Connection in psig													
		2	3	4	5	6	7	8	9	10	11	12	13	14	15
50-5	.10 (1/2")	1.6	1.9	2.3	2.6	2.8	3.0	3.2	3.4	3.6	3.8	4.0	4.2	4.3	4.4
	.22 (1/2")	3.5	4.5	5.0	5.6	6.5	6.6	7.1	7.6	8	8	9	9	10	10
	.40 (1/2")	6.4	7.6	9.1	10	11	12	13	14	15	15	16	16	17	18
	.75 (1/2")	12	14	17	19	21	23	24	26	27	28	30	31	32	33
	.95 (1/2")	15	18	21	24	27	29	31	33	34	36	38	39	40	42
	1.30 (1/2")	21	24	29	33	36	39	42	44	47	49	51	53	55	57
	1.75 (1/2")	28	33	40	44	49	52	56	60	63	66	69	72	74	76
	2.20 (1/2")	35	41	50	55	61	66	71	75	79	82	86	90	93	95
	2.80 (1/2")	45	53	64	70	78	84	90	96	100	104	109	114	118	121
	3.25 (1/2")	52	61	73	82	90	96	104	110	116	121	127	132	137	140
	4.40 (1/2")	70	83	98	110	121	130	141	149	157	163	172	178	185	190

Metric Conversion lbs/hr x .4536 = kg/hr 1 psig x 6.895 = kpa

Table 10 Recommended Qty of Tubes and Unit Weights

Duct Height in inches (cm)	Qty of Tubes	Weight in pounds (kg)ΔΔ
6-9" (15.2-22.7)	2	29.5 (13.5)
10-12" (25.4-30.5)	3	31.0 (14.1)
13-15" (33.0-38.1)	4	32.5 (14.7)
16-18" (40.6-45.7)	5	34.0 (15.4)
19-24" (48.3-61.0)	6	35.5 (16.1)

ΔΔ The weights shown include: the separator, injection tube, valve, pneumatic actuator, strainer, and two float & thermostatic traps.



Fig. N—Area Type

Reference piping notes located in the lower right corner of this page.

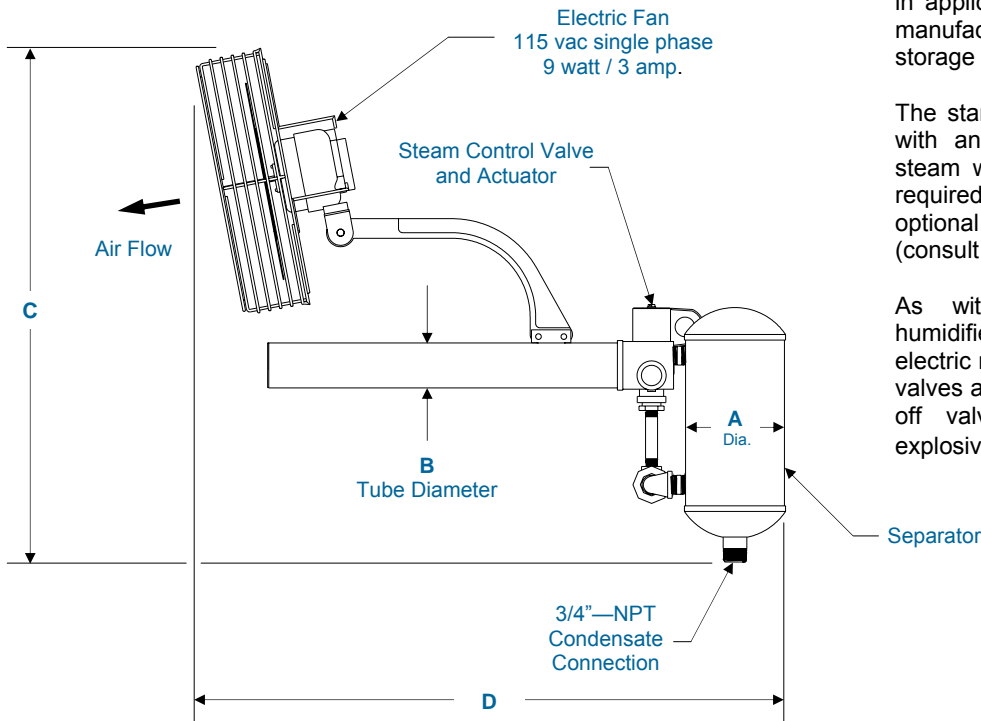

Area Type Humidifiers

Area Type tube humidifiers from PURE Humidifier Company include all the features of the single tube units. However, the Area Type humidifier is designed for applications that require direct humidification without the use of duct work.

They are ideally suited for area humidity control in applications such as paper, textile, or wood manufacturing, as well as, printing plants and storage areas.

The standard Area Type humidifier is provided with an electrically operated fan to mix the steam with the surrounding air. If humidity is required in an explosive environment, an optional pneumatically driven fan is available (consult the factory).

As with all PURE Humidifier Company humidifiers, a complete line of pneumatic, electric modulating, and electric on/off controlled valves are available (electric modulating and on/off valve actuators are not available for explosive environments).

Table 11 Area Type Humidifier Steam Capacity in pounds per hour (lbs/hr)

Model Number	Valve Cv (Size-NPT)	Steam Pressure to Humidifier Supply Connection in psig													
		2	3	4	5	6	7	8	9	10	11	12	13	14	15
A50	.10 (1/2")	1.6	1.9	2.3	2.6	2.8	3.0	3.2	3.4	3.6	3.8	4.0	4.2	4.3	4.4
	.22 (1/2")	3.5	4.5	5.0	5.6	6.5	6.6	7.1	7.6	8	8	9	9	10	10
	.40 (1/2")	6.4	7.6	9.1	10	11	12	13	14	15	15	16	16	17	18
	.75 (1/2")	12	14	17	19	21	23	24	26	27	28	30	31	32	33
	.95 (1/2")	15	18	21	24	27	29	31	33	34	36	38	39	40	42
	1.30 (1/2")	21	24	29	33	36	39	42	44	47	49	51	53	55	57
	1.75 (1/2")	28	33	40	44	49	52	56	60	63	66	69	72	74	76
	2.20 (1/2")	35	41	50	55	61	66	71	75	79	82	86	90	93	95
	2.80 (1/2")	45	53	64	70	78	84	90	96	100	104	109	114	118	121
3.25 (1/2")	52	61	73	82	90	96	104	110	116	121	127	132	137	140	
A60	5.50 (3/4")	85	104	123	138	150	161	176	186	196	204	213	222	231	236

Metric Conversion lbs/hr x .4536 = kg/hr 1 psig x 6.895 = kpa

Table 12 Dimensions & Unit Weights

Dimensions in inches (cm)	Model Number	
	A50	A60
Dim. "A"	4.5" (11.4)	5.5" (14.0)
Dim. "B"	2.0" (5.1)	2.0" (5.1)
Dim. "C"	22.7" (57.6)	24.2" (61.5)
Dim. "D"	24.1" (61.2)	25.1" (63.8)
Strainer Size	3/4"-NPT	3/4"-NPT
Steam Inlet	3/4"-NPT	3/4"-NPT
Weight in pounds (kg) ΔΔ	Model Number	
	A50	A60
	18.5 (8.4)	21.5 (9.8)

ΔΔ The weights shown include: the separator, injection tube, valve, pneumatic actuator, strainer, and F & T trap.

Piping Notes:

1. A steam trap and strainer (not shown in the above illustration) are provided with each Area Type steam injection humidifier.
2. On installation, allow 3 to 4 feet (7.6 to 10.2 cm) above the humidifier to prevent the rising steam from condensing on the ceiling.
3. When piping, take steam supply from the top of the steam main. The steam trap should drain to a return line with no back pressure; a check valve should be utilized.



System 1

In this simple heating/ventilating system, the desired location of the humidifier is downstream from the fan. The use of a high-limit duct humidistat is recommended if operating conditions are such that saturation could be reached in the duct. The high-limit humidistat should be 12 to 14 feet (365-427 cm) downstream from the humidifier injection tube. A space humidistat controls the humidifier.

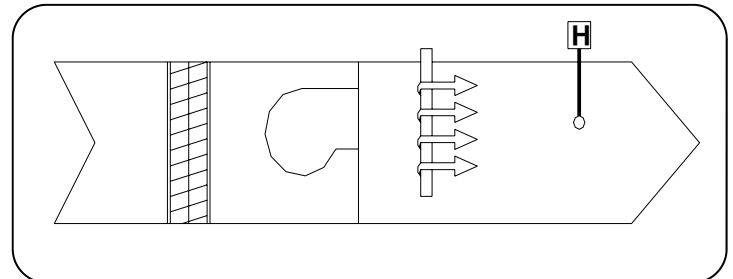

System 2

This is a 100% outside air system with preheat and reheat coils. The desired location of the primary humidifier is downstream from the reheat coil where air temperature is highest. Where operating conditions vary considerably from design, two humidifiers may be used; control is sequenced from a single space or exhaust air duct humidistat. The first humidifier will deliver one-third of the total capacity. The second humidifier is sized for two-thirds of the total capacity. When control is sequenced in this manner, much closer control is achieved.

When outdoor air conditions are milder, the first humidifier will satisfy the space conditions by supplying a portion of the total design capacity. As the outside air becomes colder and humidity demand increases, the second unit begins to open in response to the additional demand. When the humidifiers are sequenced as described, much closer control is achieved over a wide range of outside air conditions and super saturation of the duct at minimum humidification load is avoided. Use of a high-limit controller is desirable.

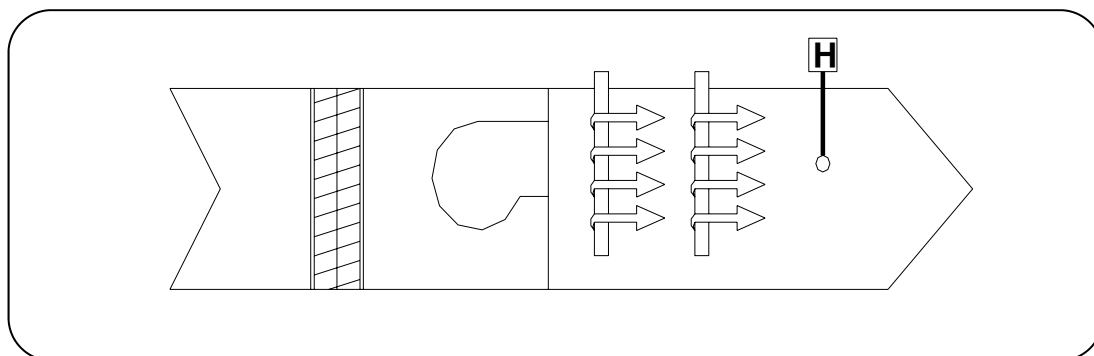



System 3

Shown here is a 100% outside air system using a primary and secondary humidifier. In this system, the primary humidifier is controlled by a duct humidistat 12 to 14 feet (366-427 cm) downstream from the humidifier and at a level that maintains a space condition of about 35% R.H. at 70°F. The secondary humidifier is controlled by a space humidistat. The secondary unit can be sized to boost space R.H. from 35% R.H. to a higher level such as 55% R.H. Combining humidifiers in this manner allows humidity for each zone to be controlled at a level higher than would otherwise be possible.

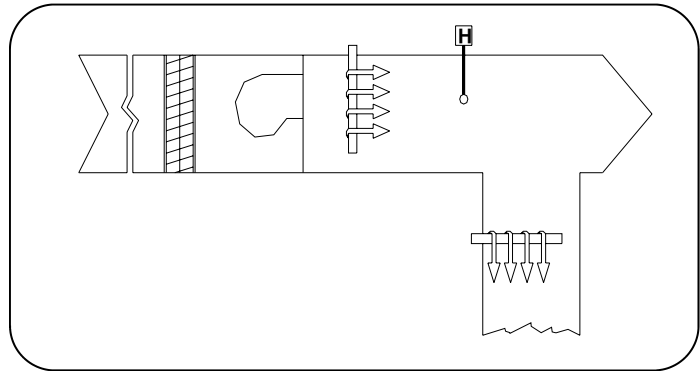

System 4

This is a high velocity, dual duct system. In this system, best results are achieved with primary and booster humidification. The primary humidifier is located as far upstream as possible from the fan and is controlled by a duct humidistat located ahead of the hot and cold deck coils. The booster humidifier is located downstream from the mixing box and is controlled by a humidistat in the space. The primary humidifier should be located no closer than 3 feet (91 cm) from the fan and the booster humidifier no closer than 3 feet (91 cm) from the grill. In both cases, the use of multiple injection tube units should be considered.

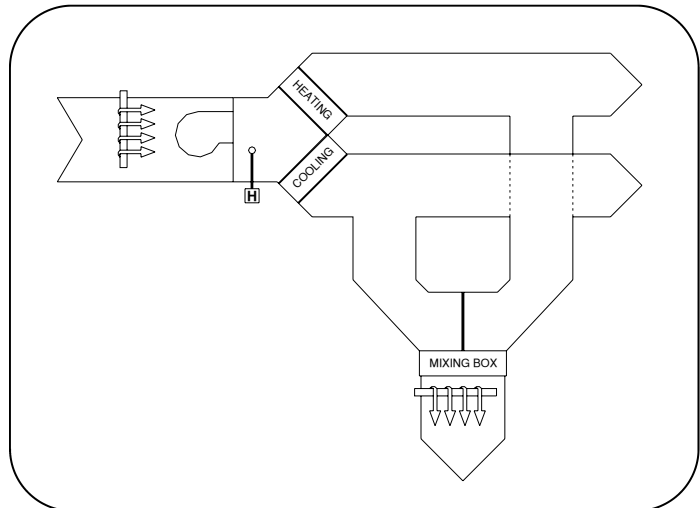

System 5

System 5 is a simple face and bypass unit. The humidifier is located downstream from the damper section so moisture enters the air stream in the area where best mixing and air temperature conditions exist.

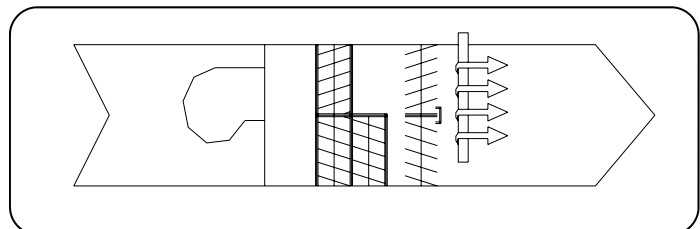



Single Tube Humidifiers

1. The humidifier shall be capable of removing condensate from the steam by means of a stainless steel condensate/steam separator, for the purpose of providing condensate-free steam.
2. Steam shall be injected into the air system through a round, stainless steel, steam jacketed injection tube. The tube shall be steam jacketed at supply pressure to assure condensate-free vapor. The steam emission ports shall be precision punched and shall be of sufficient size and number to provide constant and uniform distribution of the steam over the entire width of the duct.
3. The injection tube(s) shall be insulated (optional); insulation of the injection tube shall be done with ½" fiberglass insulation material, surrounded with 24 gauge stainless steel.
4. A normally closed control valve shall have equal percentage flow characteristics, shall close off against the steam, and shall be of sufficient capacity as required. The valve operator, pneumatic modulating (standard) or electric modulating (optional) shall be supplied by PURE Humidifier Company.
5. The humidifier shall be supplied with a float and thermostatic condensate trap, pipe line strainer, and duct plate (to seal completely at duct opening).
6. The humidifier shall be a PURE Humidifier Company humidifier as manufactured by PURE Humidifier Company, Chaska, Minnesota.

Multiple Tube Humidifiers

1. The humidifier shall be capable of removing condensate from the steam by means of a stainless steel condensate/steam separator, for the purpose of providing condensate-free steam.
2. Steam shall be injected into the air system through a round, stainless steel, steam jacketed injection tube. The tube shall be steam jacketed at supply pressure to assure condensate-free vapor. The steam emission ports shall be precision punched and shall be of sufficient size and number to provide constant and uniform distribution of the steam over the entire width of the duct.
3. The injection tube(s) shall be insulated (optional); insulation of the injection tube shall be done with ½" fiberglass insulation material, surrounded with 24 gauge stainless steel.
4. A normally closed control valve shall have equal percentage flow characteristics, shall close off against the steam and shall be of sufficient capacity as required. The valve operator, pneumatic modulating (standard) or electric modulating (optional) shall be supplied by PURE Humidifier Company.
5. The humidifier shall be supplied with float and thermostatic condensate traps, pipe line strainer, and duct plate (to seal completely at duct opening).
6. The humidifier shall be a PURE Humidifier Company humidifier as manufactured by PURE Humidifier Company, Chaska, Minnesota.

Mini-Mult Humidifiers

1. The humidifier shall be capable of removing condensate from the steam by means of a stainless steel condensate/steam separator, for the purpose of providing condensate-free steam.
2. Steam shall be injected into the air system through a round, stainless steel, steam jacketed injection tube. The tube shall be steam jacketed at supply pressure to assure condensate-free vapor. The steam emission ports shall be precision punched and shall be of sufficient size and number to provide constant and uniform distribution of the steam over the entire width of the duct without the use of inserts.
3. The injection tubes shall be completely factory welded to a stainless steel "tube manifold" and the tube assembly shall be piped to the separator assembly, ready for installation and piping connections.
4. The injection tube(s) shall be insulated (optional); insulation of the injection tube shall be done with ½" fiberglass insulation material, surrounded with 24 gauge stainless steel.
5. A normally closed control valve shall have equal percentage flow characteristics, shall close off against the steam, and shall be of sufficient capacity as required. The valve operator, pneumatic modulating (standard) or electric modulating (optional) shall be supplied by PURE Humidifier Company.
6. The humidifier shall be supplied with two float and thermostatic condensate traps (shipped loose), pipe line strainer (shipped loose), and duct plate (to seal completely at duct opening).
7. The humidifier shall be a PURE Humidifier Company humidifier as manufactured by PURE Humidifier Company, Chaska, Minnesota.

Area Type Humidifiers

1. The humidifier shall be capable of removing condensate from the steam by means of a stainless steel condensate/steam separator, for the purpose of providing condensate free steam.
2. Steam shall be injected into the air system through a round, stainless steel, steam jacketed injection tube. The tube shall be steam jacketed at supply pressure to assure condensate-free vapor.
3. A normally closed control valve shall have equal percentage flow characteristics, shall close off against the steam, and shall be of sufficient capacity as required. The valve operator (pneumatic modulating standard) or electric modulating (optional) shall be supplied by PURE Humidifier Company.
4. The humidifier shall be supplied with a float and thermostatic condensate trap, pipe line strainer, and duct plate (to seal completely at duct opening).
5. An electrical fan (pneumatic fan optional) shall be provided to add auxiliary air movement to the emitted steam.
6. The humidifier shall be a PURE Humidifier Company humidifier as manufactured by PURE Humidifier Company, Chaska, Minnesota.



Condensate Return Line

In order for the steam trap to remove condensate, it is essential that pressure in the condensate return line be substantially below the steam's supply pressure. In the event the return line is at a higher elevation than the steam trap, the trap should be drained to a floor drain or the condensate must be elevated. In elevating condensate, an intermittent discharge trap, such as an inverted bucket type, should be used. Every 2 psi (13.8 kpa) of steam pressure will elevate the condensate one foot (30.5 cm). Also, a check valve must be installed on the outlet of the steam trap to prevent back flow of the elevated condensate into the humidifier.

Expanded Duct Section

To avoid restricting air flow in a duct 8 inches (20.3cm) or less in height, use of an expanded duct section is recommended.

Proper Length Injection Tubes

For best dissipation of the steam into the air stream, always use injection tubes that fully span the widest dimension of the duct.

Vertical Tube Humidifiers

In those installations where the duct is taller than it is wide, a vertical tube humidifier may be used to gain tube length. NOTE: Vertical tube humidifiers must always be installed with the tube(s) pointing upwards to avoid trapping condensate in the outboard end of the injection tube.

Insulated Injection Tubes

Where specifications require, insulated injection tubes are available. The insulation is 1/2" (1.3 cm) fiberglass covered with a 24 gauge stainless steel jacket. NOTE: Insulated injection tubes must be installed with the stream emitting with the air flow to prevent condensation on the outer insulation jacket.

Fan Interlock Switch

PURE Humidifier Co. recommends the use of an air flow proving switch or fan interlock to prove air flow prior to humidifier operation. Humidifier operation without air flow will result in over-saturation of the air stream. Air flow proving switches are available as optional equipment from your PURE Humidifier Company representative.

High-Limit Humidistat

PURE Humidifier Co. recommends the use of a duct high-limit humidistat to prevent humidifier operation when the duct humidity level exceeds 85% relative humidity. Humidifier operation above 85% relative humidity can result in over saturation of the air stream. High-limit humidistats are available as optional equipment from your PURE Humidifier Company representative.

Temperature Interlock Switch

PURE Humidifier Co. recommends the use of an Interlock temperature switch on applications with steam pressures below 5 psi (34.5 kpa) or as a safety switch to prevent humidifier operation in the case of a boiler or trap malfunction. Interlock temperature switches (pneumatic or electric) are available as optional equipment from your PURE Humidifier Company representative.

Location of Humidifiers

Humidifiers should be located:

1. In the center of duct or air handling unit.
2. Not less than 3 feet (91.4 cm) upstream from fan inlets, tees, "ells", turning vanes, discharge grills or other in-duct objects.
3. Not less than 10 feet (304.8 cm) upstream from high efficiency filters.
4. Not less than 10 feet (304.8 cm) upstream from humidity or temperature controllers.