



*Deionized, Demineralized, or Reverse Osmosis Water*

# *"ESDDR" Series Electric Humidifier*

The "ESDDR" Series Electric Humidifier from PURE Humidifier Company is loaded with features and options. All you need is deionized, demineralized, or reverse osmosis water, electricity, and a sanitary drain. The humidifier does the rest.

These units are designed to operate with absolutely pure water, which is corrosive and will not conduct electricity. They feature special stainless steel construction with special assembly techniques to assure corrosion-resistant joints.

The water level is maintained with a special float valve to control the water level (instead of the Tri-Probe electronic water level controller that is utilized on the "ES" Series). A low water cut-off switch is utilized to protect the heating elements. Both floats are protected from water turbulence by an internal baffle. Since the reservoir's water level is automatically and constantly adjusted, there is no downtime; steam is always available.

A control panel with a microprocessor controller mounted on the panel door constantly monitors the humidifier cycle for efficient operation. The microprocessor controller also provides a vacuum fluorescent display to indicate the status of the humidifier. High efficiency immersion water heaters (up to twelve) heat the water to provide steam. Furthermore, a water overflow safety pipe is standard on all "ESDDR" units.

Since the water mineral build-up does not occur with pure water, there is no need for an automatic drain system or cleaning. These units are practically maintenance-free.

When it comes to installation, you have a choice with the "ESDDR" Series Electric Humidifier. The humidifier can be free-standing with a simple (optional) flexible hose connecting the unit to the stainless steel injection tube inserted through the duct wall. You can also mount the unit on the wall with wall brackets, or floor-mounted with support legs (both optional). For mounting under a duct, you simply need hangers and support brackets.

These humidifiers can also be mounted inside the air handling system (local codes may require moisture-proof construction of certain components). Fast-Pac or Insty-Pac tube assemblies can be provided for short dissipation in any built-up or manufactured air handling system.

The versatility of the "ESDDR" Series Electric Humidifier will allow you to design them into any system simply, efficiently, and reliably.



Deionized Water Unit Model No.	Steam Output Capacity †		KW	Humidifier Reservoir Weight*				Control Cabinet Weight Δ	
	lbs/hr	kg/hr		Empty		Full		lbs	kg
ESDDR-3	9.0	4.1	3	50.5	22.9	130.5	59.2	32.0	14.5
ESDDR-4.5	13.5	6.1	4.5	50.5	22.9	130.5	59.2	32.0	14.5
ESDDR-5.5	16.5	7.5	5.5	50.5	22.9	130.5	59.2	32.0	14.5
ESDDR-7.5	22.5	10.2	7.5	50.5	22.9	130.5	59.2	32.0	14.5
ESDDR-11	31.5	14.2	11	50.5	22.9	130.5	59.2	32.0	14.5
ESDDR-14	40.5	18.4	14	50.5	22.9	130.5	59.2	32.0	14.5
ESDDR-15	45.0	20.4	15	50.5	22.9	130.5	59.2	32.0	14.5
ESDDR-16.5	49.5	22.5	16.5	50.5	22.9	130.5	59.2	32.0	14.5
ESDDR-19.5	58.5	26.5	19.5	50.5	22.9	130.5	59.2	32.0	14.5
ESDDR-22	63.0	28.6	22	61.0	27.7	177.0	80.3	55.0	25.0
ESDDR-28	81.0	36.7	28	61.0	27.7	177.0	80.3	55.0	25.0
ESDDR-30	90.0	40.8	30	61.0	27.7	177.0	80.3	55.0	25.0
ESDDR-33	99.0	45.0	33	61.0	27.7	177.0	80.3	55.0	25.0
ESDDR-39	117.0	53.1	39	61.0	27.7	177.0	80.3	55.0	25.0
ESDDR-42	126.0	57.2	42	61.0	27.7	177.0	80.3	55.0	25.0
ESDDR-45	135.0	61.2	45	65.5	29.7	181.5	82.3	72.0	32.7
ESDDR-49.5	148.5	67.4	49.5	65.5	29.7	181.5	82.3	72.0	32.7
ESDDR-58.5	175.5	80.0	58.5	65.5	29.7	181.5	82.3	72.0	32.7
ESDDR-63	189.0	85.7	63	65.5	29.7	181.5	82.3	72.0	32.7
ESDDR-66	198.0	89.8	66	88.0	39.9	243.0	110.2	72.0	32.7
ESDDR-78	234.0	106.1	78	88.0	39.9	243.0	110.2	72.0	32.7
ESDDR-84	252.0	114.3	84	88.0	39.9	243.0	110.2	72.0	32.7
ESDDR-102	306.0	138.8	102	88.0	39.9	243.0	110.2	72.0	32.7

\* When calculating the total dry weight of the humidifier, the control cabinet weight must be added to the reservoir weight.

Δ The control cabinet is shipped loose unless optional factory mounting is specified. Reference the "Dimension Sheet" for control cabinet dimensions.

† The above capacities are based on 100% efficiency. Actual humidifier capacity may vary due to the heat loss from the humidifier reservoir. The ambient air temperature, air velocity, and injection tube system will affect the rate of heat loss from the humidifier reservoir.



**NEMA- 12 Humidifier Control Cabinet**  
(reference control cabinet notes)

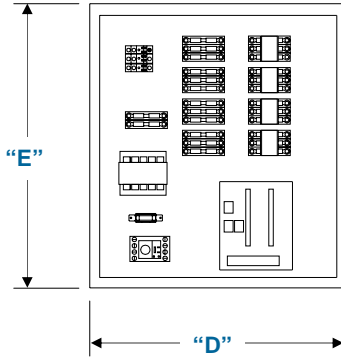

1. Door has been removed from the drawing for clarity.
2. Control cabinet is shipped loose for field mounting unless optional factory mounting is specified.
3. Dimension "F" = Control cabinet depth.

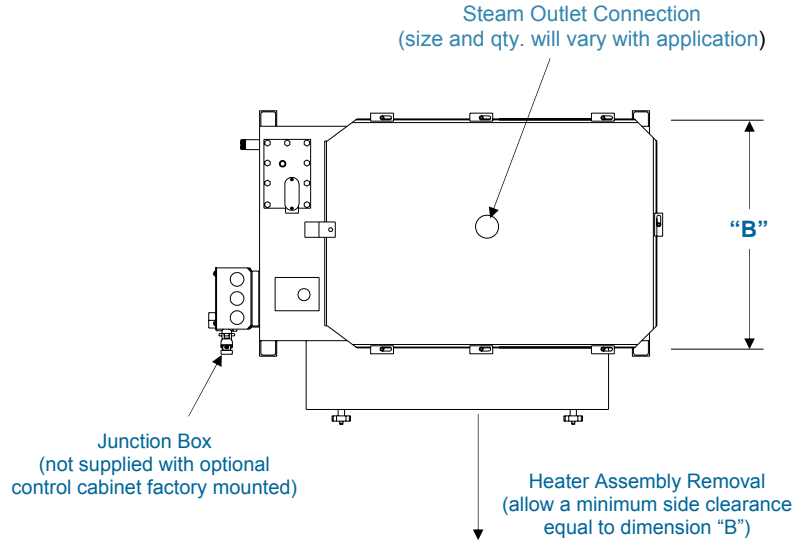

**Top View**

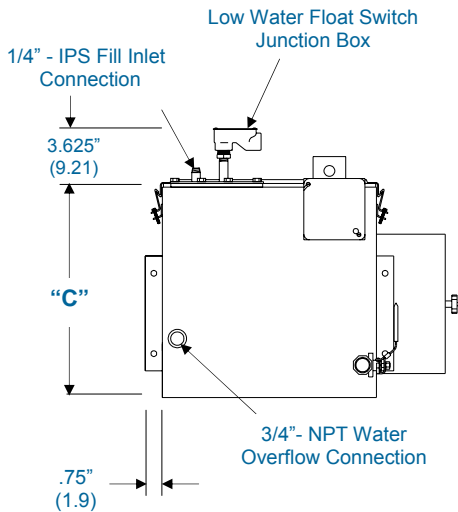

**Front View**

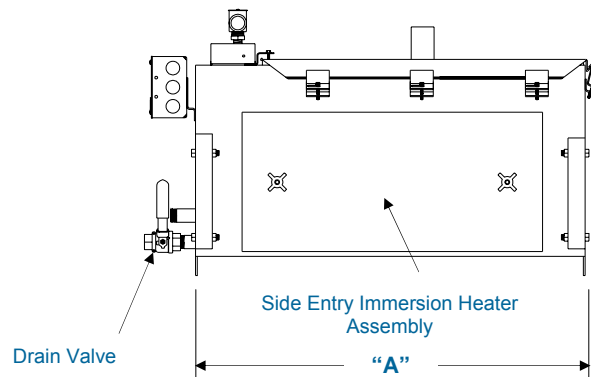

**Right Side View**

**Unit Dimensions in inches (cm)**

Model Number	Dim. "A"	Dim. "B"	Dim. "C"
ESDDR-3 thru 19.5	17.50" (44.5)	14.00" (35.6)	13.75" (34.9)
ESDDR-22 thru 63	25.50" (64.8)	14.00" (35.6)	13.75" (34.9)
ESDDR-66 thru 102	34.00" (86.4)	18.25" (46.4)	13.75" (34.9)

**Control Cabinet Dimensions in inches (cm)**

Model Number	Dim. "D"	Dim. "E"	Dim. "F"
ESDDR-3 thru 19.5	14.00" (35.6)	16.00" (40.6)	6.00" (15.2)
ESDDR-22 thru 63	20.00" (50.8)	20.00" (50.8)	7.00" (17.8)
ESDDR-66 thru 102	20.00" (50.8)	24.00" (61.0)	7.00" (17.8)



**Single Phase Amperage†**

Standard Water Unit Model No.	Unit KW	120V	208V	240V	480V	600V	No. of Heaters	Heater KW	Control Circuit Voltage
ESDDR-3	3	25.0	14.4	12.5	6.3	5.0	1	3.0	24 vac
ESDDR-4.5	4.5	37.5	21.6	18.8	9.4	7.5	1	4.5	24 vac
ESDDR-5.5	5.5	45.8	26.4	22.9	11.5	9.2	1	5.5	24 vac
ESDDR-7.5	7.5		36.1	31.3	15.6	12.5	1	7.5	24 vac
ESDDR-11	11				22.9	18.3	2	5.5	24 vac
ESDDR-14	14				29.2	23.3	2	7.0	24 vac
ESDDR-15	15				31.3	25.0	3	5.0	24 vac
ESDDR-16.5	16.5				34.4	27.5	3	5.5	24 vac
ESDDR-19.5	19.5				40.6	32.5	3	6.5	24 vac
ESDDR-22	22			91.7	45.8	36.7	4	5.5	24 vac
ESDDR-28	28				58.3	46.7	4	7.0	24 vac
ESDDR-30	30				62.5	50.0	4	7.5	24 vac
ESDDR-33	33				68.8	55.0	6	5.5	24 vac
ESDDR-39	39				81.3	65.0	6	6.5	24 vac
ESDDR-42	42				87.5	70.0	6	7.0	24 vac
ESDDR-45	45				93.8	75.0	9	5.0	24 vac
ESDDR-49.5	49.5				103.1	82.5	9	5.5	24 vac
ESDDR-58.5	58.5				121.9	97.5	9	6.5	24 vac
ESDDR-63	63				131.3	105.0	9	7.0	24 vac
ESDDR-66	66				137.5	110.0	12	5.5	24 vac
ESDDR-78	78				162.5	130.0	12	6.5	24 vac
ESDDR-84	84				175.0	140.0	12	7.0	24 vac
ESDDR-102	102				212.5	170.0	12	8.5	24 vac

**Three Phase Amperage†**

Standard Water Unit Model No.	Unit KW	208V	240V	480V	600V	No. of Heaters	Heater KW	Control Circuit Voltage
ESDDR-3	3	8.3	7.2	3.6	2.9	3	1.0	24 vac
ESDDR-4.5	4.5	12.5	10.8	5.4	4.3	3	1.5	24 vac
ESDDR-5.5	6.0	16.6	14.4	7.2	5.8	3	2.0	24 vac
ESDDR-7.5	7.5	20.8	18.0	9.0	7.2	3	2.5	24 vac
ESDDR-11	10.5	29.1	25.3	12.6	10.1	3	3.5	24 vac
ESDDR-14	13.5	37.5	32.4	16.2	13.0	3	4.5	24 vac
ESDDR-15	15	41.6	36.1	18.0	14.4	3	5.0	24 vac
ESDDR-16.5	16.5	45.8	39.7	19.8	15.9	3	5.5	24 vac
ESDDR-19.5	19.5		46.9	23.5	18.8	3	6.5	24 vac
ESDDR-22	21	58.3	50.5	25.3	20.2	6	3.5	24 vac
ESDDR-28	27	75.0	64.9	32.5	26.0	6	4.5	24 vac
ESDDR-30	30	83.3	72.2	36.1	28.9	6	5.0	24 vac
ESDDR-33	33	91.6	79.4	39.7	31.8	6	5.5	24 vac
ESDDR-39	39		93.8	46.9	37.5	6	6.5	24 vac
ESDDR-42	42			50.5	40.4	6	7.0	24 vac
ESDDR-45	45	124.9	108.3	54.1	43.3	9	5.0	24 vac
ESDDR-49.5	49.5	137.4	119.1	59.5	47.6	9	5.5	24 vac
ESDDR-58.5	58.5		140.7	70.4	56.3	9	6.5	24 vac
ESDDR-63	63			75.8	60.6	9	7.0	24 vac
ESDDR-66	66	183.2	158.8	79.4	63.5	12	5.5	24 vac
ESDDR-78	78		187.6	93.8	75.1	12	6.5	24 vac
ESDDR-84	84			101.0	80.8	12	7.0	24 vac
ESDDR-102	102			122.7	98.2	12	8.5	24 vac

† Other voltages available upon request. Please consult factory for specific availability.

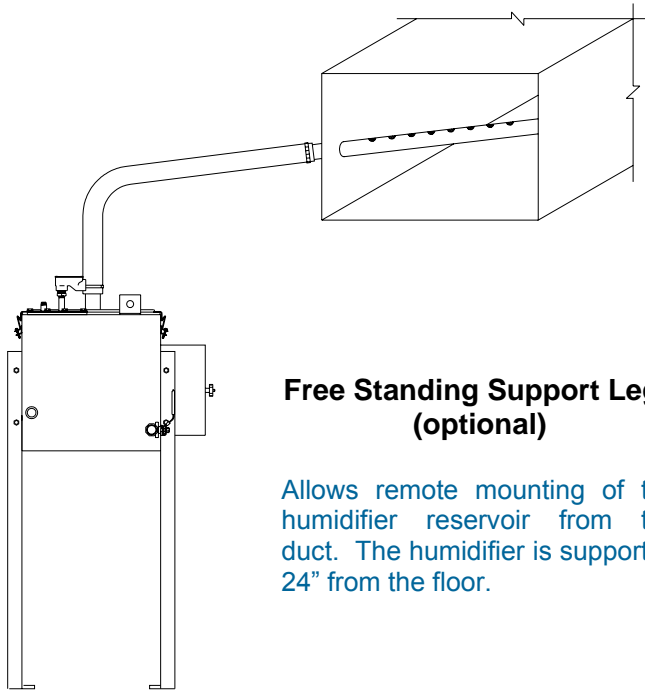

**Free Standing Support Legs  
(optional)**

Allows remote mounting of the humidifier reservoir from the duct. The humidifier is supported 24" from the floor.

The "ES" Series Electric Humidifier offers a wide variety of mounting applications. If the duct is remote from the humidifier reservoir, free-standing floor support legs or wall brackets (both optional) are available. The humidifier can even be mounted directly within an air handling unit (local codes may require moisture proof construction of certain components). Single or multiple injection tubes can be used to custom fit any duct or air handler size.

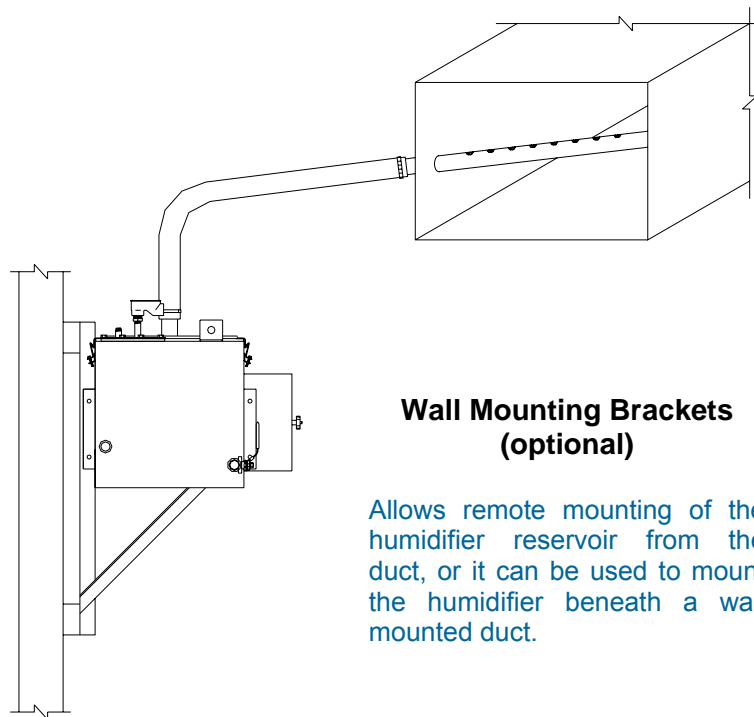

**Wall Mounting Brackets  
(optional)**

Allows remote mounting of the humidifier reservoir from the duct, or it can be used to mount the humidifier beneath a wall mounted duct.



## Humidifier

1. The humidifier shall be electrically heated immersion heater type as manufactured by PURE Humidifier Company of Chaska, Minnesota.
2. The humidifier shall be tested and approved by ETL Testing Laboratories, Inc. (ETL# 472940).
3. The humidifier shall be suitable for use with deionized, demineralized, or reverse osmosis water with a maximum purity of 18 mega ohms per square centimeter.
4. The humidifier shall have an evaporating reservoir with a gasket-sealed cover that is capable of operating at pressures of at least 19" (48 cm - W.C.) without steam or water leaks. The reservoir shall be made of type 304 stainless steel with welded joints.
5. The humidifier shall be designed to facilitate easy removal of the cover and side-entry immersion heater assembly for cleaning. A side-entry immersion heater assembly shall be incorporated into the side of the humidifier to permit easy access to immersion heater elements.
6. Humidifier shall be field-convertible from an electric immersion heater style "ESDDR" humidifier to a steam heat exchanger style "SXDDR" humidifier with a simple change of the side-entry assembly.
7. A stainless steel, float-operated low water cut-off switch shall be provided. The float switch shall provide low water cut-off of the humidifier immersion heaters.
8. The immersion heater(s) shall be incoloy clad and designed for 80 watts per square inch. They shall be attached to the reservoir cover and be easily removed for cleaning or inspection.
9. A stainless steel, float-operated water fill valve mounted on the top near the front shall be provided. The fill valve shall provide automatic refilling of the humidifier reservoir. The water inlet shall be located to allow a minimum air gap of 1-1/2" (3.81 cm).
10. The humidifier shall have a 3/4" (1.9 cm) over flow pipe to prevent overflowing of the humidifier reservoir.
11. The humidifier shall have a manual reset over-temperature switch factory-installed on the humidifier reservoir. The temperature switch shall provide humidifier over-temperature protection.
12. An INTAC<sup>®</sup> programmable microprocessor control module shall be factory-mounted on the cover of the control panel, and shall electronically control the low water cut-off and safety switch interlock functions.
13. The humidifier shall be provided with an ETL listed JIC NEMA 12 control cabinet, shipped loose (reference factory mounting option). The control cabinet shall be made of 14 gauge steel with ANSI 61 gray polyester powder coating, continuous hinge and oil-resistant gasket. The panel shall include a factory-wired sub-panel with magnetic contactor(s), time delay relay, fused control circuit transformer, numbered terminal block, and heater fuse(s).
14. The control cabinet shall have a factory-wired time delay relay circuit. The delay circuit shall prevent cycling of the low water interlock circuit due to water fluctuations within the humidifier reservoir.



An INTAC<sup>®</sup> programmable electronic microprocessor humidifier control system shall be mounted and pre-wired to the humidifier control panel door. All humidifier electrical, ground and control terminal connections shall be enclosed in an ETL listed NEMA 12 enclosure. The INTAC<sup>®</sup> controller shall provide the following standard features:

- Self-diagnostics and system verification on start-up.
- Cold water tempering prevents excessively hot water from draining during automatic or seasonal drain cycle.
- Safety circuit input terminals including over-temperature shut down.
- Terminal connections to accept virtually all control input signals. Input control range is selected as an "ON-SCREEN" prompt.
- Door-mounted display and user interface. Provides two lines of system messaging on a vacuum fluorescent display screen, LED operational indication, and keypad parameter entry system.
- Time delayed scrolling display loop – displays all system parameters and alarms in a scrolling loop every ten minutes or upon key press. The Display Loop includes: System Status, Actual Space RH, Duct RH (optional), High-Limit RH (optional), Outdoor Air Temperature (optional), Power Output, Humidifier/System Capacity (in lbs/hr or kg/hr), and Control Type.
- Time-to-Service message.
- Numbered screen prompts for set-up and service identification.
- Full "ON-SCREEN" help information at all displays, prompts, alarms, or errors. The "HELP" message includes on screen diagnostic assistance.
- Keypad lock-out with user selected access levels.
- Terminal connections for a remote keypad display module.

- Networking and BAS communication ports. Communication ports shall provide two-way communication between the INTAC<sup>®</sup> controller and the Building Automation System (BAS), if utilized.
- High/Low humidity deviation alarm contacts (modulating control only).
- Fault alarm contacts.
- Flash Memory – allows system upgrades with a laptop computer, via RS-232 port on the INTAC<sup>®</sup>.

#### OPTIONAL FEATURES

- A. Time Cycle Modulation. Provides 0-100% time proportioned control of the heater output. A compatible humidity sensor shall be shipped loose for field installation ( $\pm 3-4\%$  RH).
- B. SCR Modulation. Provides 0-100% power modulation of the heater outputs down to a one-second cycle rate. A compatible humidity sensor shall be shipped loose for field installation ( $\pm 1-2\%$  RH).
- C. Variable Air Volume (VAV) anticipation control. The INTAC<sup>®</sup> software shall accept a modulating high-limit humidity input and space controlling RH input and modulate the output to prevent over saturation of the supply air due to changes in the air flow. A compatible humidity sensor shall be shipped loose for field installation.
- D. Cold weather relative humidity reset. The INTAC<sup>®</sup> software shall accept a modulating temperature input and automatically reduce the space RH set-point on a drop in the outside temperature. The reduction of the RH set-point during cold weather periods prevents damage due to interior window condensation.
- E. Reservoir thermocouple water control. The INTAC<sup>®</sup> software provides stand-by water sensing and freeze protection.
- F. A remote wall mount INTAC<sup>®</sup> user interface keypad/display module shall be furnished.



### Humidifier

**Insulation.** Unit shall be covered (except top cover) with 3/4" (1.9 cm) thick fiberglass duct insulation. Insulation material shall have aluminum foil facing.

**Freeze Protection.** A factory-installed temperature sensor shall be mounted onto the humidifier reservoir. The system shall maintain the water temperature above freezing.

**Stand-by Water Temperature Sensing.** Consists of a temperature sensor to maintain water temperature at a selected level for fast response upon a call for humidity.

### Mounting

**Support Legs.** Provide support legs made of 1-1/4" x 1-1/4" x 1-1/4" (3.2 cm) angle iron and painted with enamel gray paint. Distance from humidifier bottom to floor shall be 24" (61 cm).

**Wall Brackets.** Provide two wall brackets made of 1-1/4" x 1-1/4" x 1-1/4" (3.2 cm) angle iron and painted with enamel gray paint.

### Injection Tubes

**Injection Tube(s) and Flexible Hose.** Each unit shall include one or more 10-foot (305 cm) sections of 1-1/2" (3.8 cm) I.D. flexible hose and a 1-1/2" (3.8 cm) O.D. stainless steel injection tube long enough to extend across the duct. Steam ports shall direct steam upward into the airflow. The reservoir cover shall have a matching connection so the flexible hose can be connected with two stainless steel hose clamps. A two-piece duct plate shall be provided to seal the duct opening.

**Fast-Pac Multiple Tube Assembly.** Tube assembly consists of a stainless steel supply/condensate header with a 3/4"-NPT drain connection and horizontal 1-1/2"Ø stainless steel injection tubes.

**Insty-Pac Tube Assembly.** Tube assembly consists of a steam supply/seperator header constructed of stainless steel with steam inlet, condensate drain outlet, and steam jacketed injection tubes welded to header. Steam jacketed injection tubes constructed of stainless steel with punched steam ports of the proper size and spacing to deliver the maximum specified capacity.

**Zone Control.** A separate flexible hose kit with 24 volt zone control valve with sensor (optional) will be provided for each zone specified. The zone valve will be sized to provide capacity requirements without exceeding 2" (5 cm) W.C. pressure drop. The humidifier shall require one heater contactor per zone and on humidity demand the zone valve shall energize the appropriate heaters (on/off control).

### To Control Cabinet

**Control Cabinet Factory Mounting.** Humidifier control cabinet shall be factory-mounted and wired to the left side of the humidifier.

**NEMA 4 Control Cabinet.** A NEMA 4 weather-tight control cabinet shall be substituted for the standard NEMA 12 cabinet.

**Control Panel Door Lock.** Control cabinet shall be provided with a factory-installed key lock on the cabinet door.

### Modulating Controls (select one)

**Time Cycle Modulation.** A TCM controller shall be factory-mounted and wired on the control panel and provide modulating control of the humidifier capacity from 0-100%. The heaters shall be time cycle modulated according to the humidistat demand. A modulating wall humidistat (shipped loose) shall be provided with the system.

**SCR Controller.** A 100% solid state power controller shall be provided on the control panel with a matching modulating wall humidistat (shipped loose). The SCR power controller will modulate the humidifier between 0-100% of its rated capacity according to humidistat demand.

### Controls

**VAV Control.** The INTAC® software shall accept a modulating high-limit input and space controlling RH input and modulate the heater output to prevent over saturation of the supply air due to changes in the quantity of airflow. A compatible space and duct humidity sensor shall be shipped loose for field installation.

**Outdoor Air Temperature Setback.** Provides automatic reduction of RH set-point to prevent condensation on windows during extreme cold weather.

**Air Flow Proving Switch.** A diaphragm operated air flow proving switch with adjustable control range of .05" W.C. to 12.0" W.C. shall be provided for field installation. Switch rating shall be 2.5 amps at 120V.

**Duct High-Limit.** A high-limit humidistat shall be provided for duct installation. The high-limit shall be field set to prevent over saturation within the supply duct.