



Standard Water

"EC" Series

Electric Humidifier

The "EC" Series electric humidifier from PURE Humidifier Co is loaded with features and options. All you need is tap water, electricity, and a sanitary drain. The humidifier does the rest.

These units feature a Tri-Probe electronic water level control system made up of three Teflon® coated stainless steel probes. The lower probe prevents the heating elements from energizing when the water level is too low. The middle probe electrically activates the water control valve to fill the reservoir. The top probe shuts off the water control valve when the water level reaches the proper height. A self-contained control panel with an electronic controller mounted within constantly monitors the humidifier cycle for efficient operation. The electronic controller also provides LED indicators to indicate the status of the humidifier. High efficiency immersion water heaters heat the water to provide steam. An accumulative timed drain cycle performs automatic draining and flushing, thus reducing mineral build-up within the reservoir.

All this is contained within an aesthetically pleasing cabinet that is constructed of 18-gauge steel with a baked enamel paint finish. The cabinet floor is designed as a drain pan with plumbing connections for drain piping. The cabinet is designed to be compact for easy installation and maintenance. The internal stainless steel evaporating chamber is mounted on slides for easy removal. The electrical compartment is isolated from the evaporating chamber and is supplied with a key locked door.

When it comes to installation, you have a choice with the "EC" Series electric humidifier. The humidifier can be wall mounted with a simple flexible hose connecting the unit to the stainless steel injection tube inserted through the duct wall. You can also mount the unit on the wall with the optional blower pack for direct room humidification. The Blower Pack can be mounted directly on top of the "EC" humidifier or remote mounted, and contains a whisper-quiet adjustable speed fan to disperse the steam directly into the space without the use of ductwork.

These humidifiers can also be mounted inside the air handling system (local codes may require moisture-proof construction of certain components). Multiple injection tubes can be provided to custom fit any built-up or manufactured air handling system.

The versatility of the "EC" Series electric humidifier will allow you to design them into any system simply, efficiently, and reliably. Capacities range up to 102 lbs/hr.

Note: Also available is the "ECDDR" Series electric humidifier which is designed for use with deionized, demineralized, or reverse osmosis water. It is designed for corrosive water that will not conduct electricity. Since mineral build-up does not occur with pure water, there is no need for an automatic drain system or cleaning. These units are practically maintenance-free.

EC-5	EC-10	EC-15	EC-20	EC-25	EC-35
15 lbs/hr (6.8 kg/hr)	30 lbs/hr (13.6 kg/hr)	45 lbs/hr (20.4 kg/hr)	60 lbs/hr (27.2 kg/hr)	75 lbs/hr (34.0 kg/hr)	102 lbs/hr (46.3 kg/hr)

Our results are comforting



Capacity & Weights
“EC” Series

Standard Water Unit Model No.	Steam Output Capacity †		Humidifier Weight			
	lbs/hr	kg/hr	Empty		Full	
			lbs	kg	lbs	kg
EC-5	15.0	6.8	139.0	63.1	223.0	101.2
EC-10	30.0	13.6	140.0	63.5	224.0	101.6
EC-15	45.0	20.4	141.0	64.0	225.0	102.1
EC-20	60.0	27.2	142.0	64.4	226.0	102.5
EC-25	75.0	34.0	143.0	64.9	227.0	103.0
EC-35	102.0	46.3	146.0	66.2	230.0	104.3

Electrical Specifications
“EC” Series

Standard Water Unit Model No.	KW	No. of Heaters	Single Phase Amperage					Three Phase Amperage				Control Circuit Voltage	
			120V	208V	240V	480V	600V	No. of Heaters	208V	240V	480V		600V
EC-5	5	Single	41.7	24.0	20.8	10.4	8.3	Triple	13.9	12.0	6.0	4.8	24 vac
EC-10	10	Double			41.7	20.8	16.7	Triple	27.8	24.1	12.0	9.6	24 vac
EC-15	15	Triple				31.3	25.0	Triple	41.7	36.1	18.1	14.4	24 vac
EC-20	20	Triple				41.7	33.3	Triple		24.1	19.2		24 vac
EC-25	25	Triple				41.7		Triple		30.1	24.1		24 vac
EC-35	34	Triple						Triple		40.9	32.7		24 vac

† The above capacities are based on 100% efficiency. Actual humidifier capacity may vary due to the heat loss from the humidifier reservoir. The ambient air temperature, air velocity, and injection tube system will affect the rate of heat loss from the humidifier reservoir.

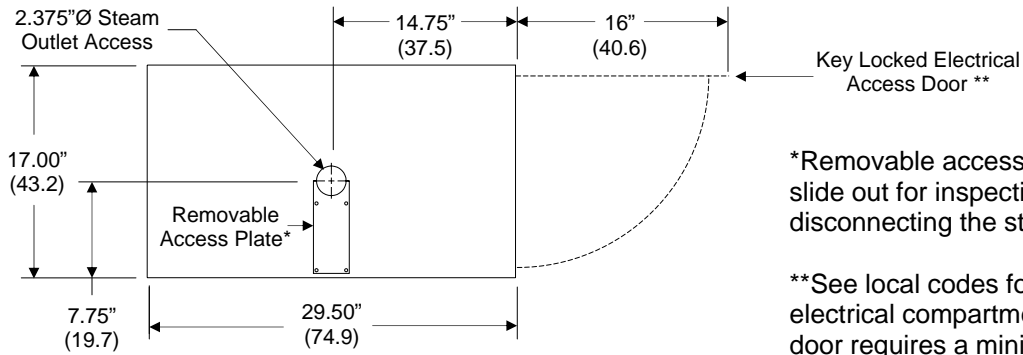

*Removable access plate allows reservoir to slide out for inspection and cleaning without disconnecting the steam supply piping.

**See local codes for minimum clearance to electrical compartment. The electrical access door requires a minimum clearance of 16" to fully open.

TOP VIEW

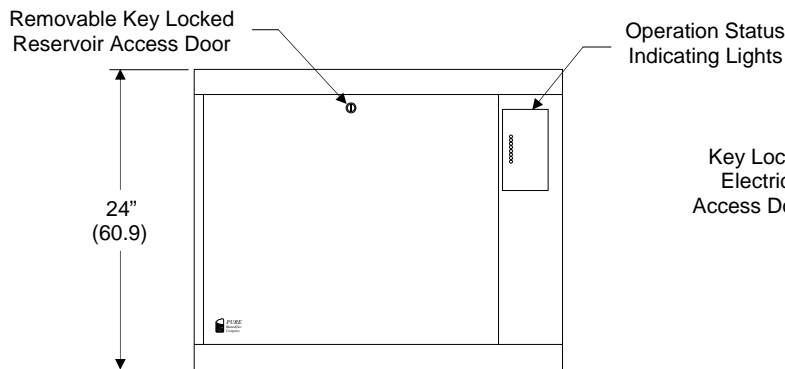

FRONT VIEW

RIGHT SIDE VIEW

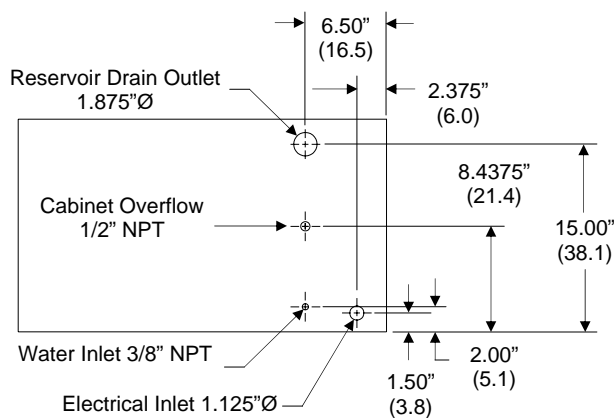

BOTTOM VIEW

Note: Dimensions are typical for all EC models.

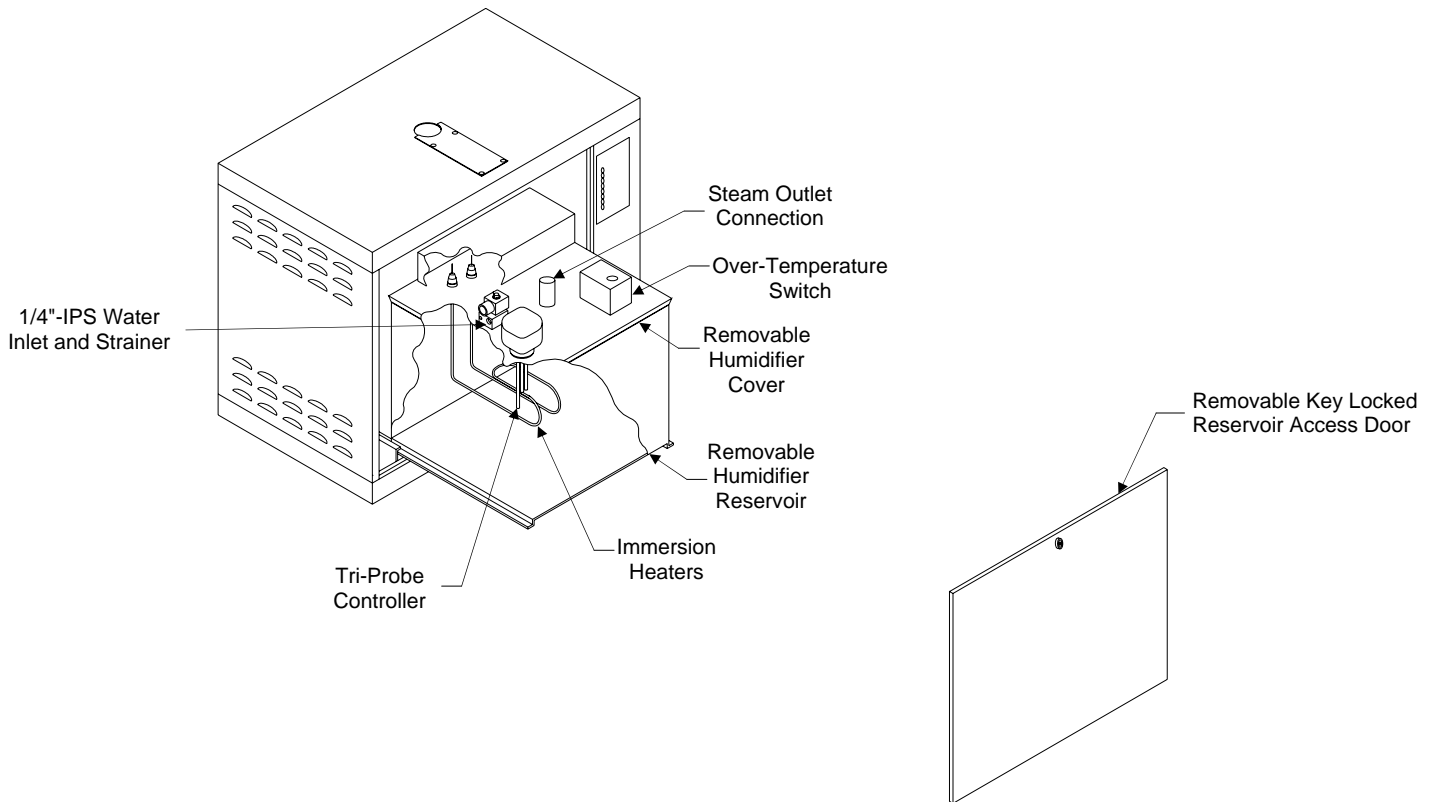

Humidifier Features

- On/Off, Time Cycle Modulation* or SCR* control
- Visible status and diagnostic LED indicator lights
- Electronic water level control system
- Accumulative automatic timed drain system
- Seasonal end-of-use drain system*
- High efficiency incoloy immersion water heaters
- 18 gauge steel cabinet with baked enamel paint finish
- Internal stainless steel evaporating reservoir mounted on slides for easy removal
- Key locked doors for both reservoir and electrical access
- Easy and simple installation options
- Dispersion methods include Insty-Pac*, Fast-Pac* hose kit*, or blower pack assembly* for room distribution
- Manual reset over-temperature safety switch
- INTAC® microprocessor control system*
- VAV dual modulating control system*

* Optional features

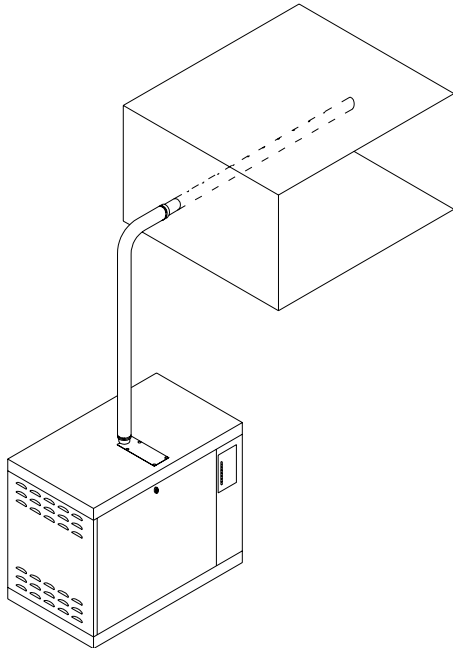

Flexible Hose Kit

Allows remote mounting of the humidifier reservoir from the duct. Also allows the humidifier to be located below a wall-mounted duct.

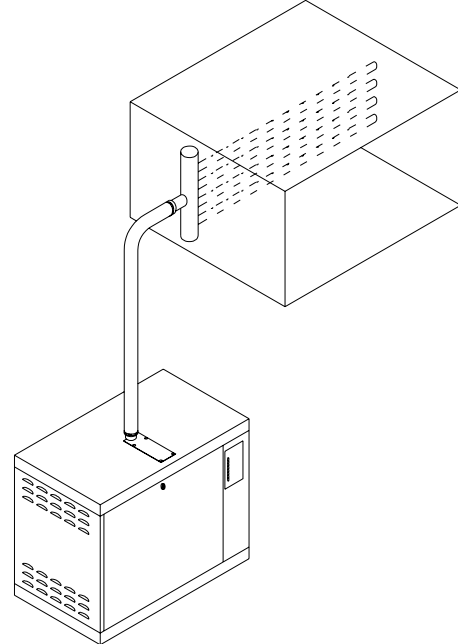

**Insty-Pac and Fast-Pac
Multiple Injection Tube Assemblies**

For applications where you need a short dissipation distance. Allows remote mounting of the humidifier reservoir from the duct. Also allows the humidifier to be located below a wall-mounted duct.

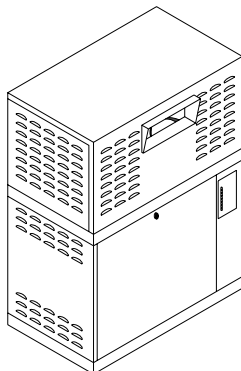

Blower Pack for Direct Room Humidification

Allows humidifier to be mounted directly on the wall within the space to be humidified.



Optional Blower Pack

In applications where a ducted air system is not available, PURE offers the optional Blower Pack. The Blower Pack contains a two-speed adjustable blower that moves the air over the steam discharge outlet and disperses the steam directly into the space (see Fig. 1). The Blower Pack mounts directly on top of the "EC" humidifier or can be mounted remotely (see Fig. 2).

Locating Blower Pack

The distance that visible steam will travel after leaving the Blower Pack is dependent upon the relative humidity in the room and the capacity of the humidifier. If this visible steam comes in contact with any solid object (walls, beams, machinery, etc.) it may form condensate and drip. Refer to Fig. 3 and Table 4 (Table 4 is located on page EC-7) for data on visible steam travel. This will aid you in planning the location of the Blower Pack.

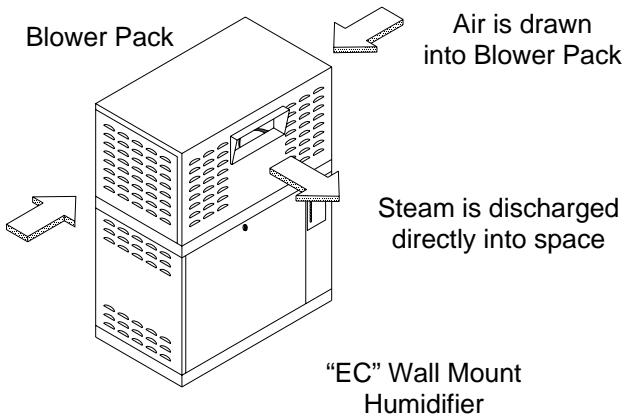

"EC" With Optional Blower Pack
Fig. 1

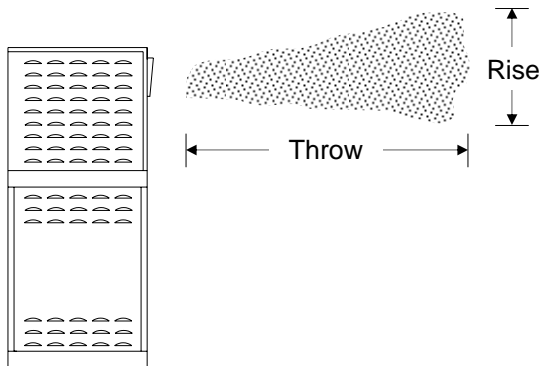

Visible Rise and Throw
Fig. 3

Remote Mounting

The Blower Pack may be remote mounted up to ten feet away from the "EC" wall mount humidifier (see Fig. 2).

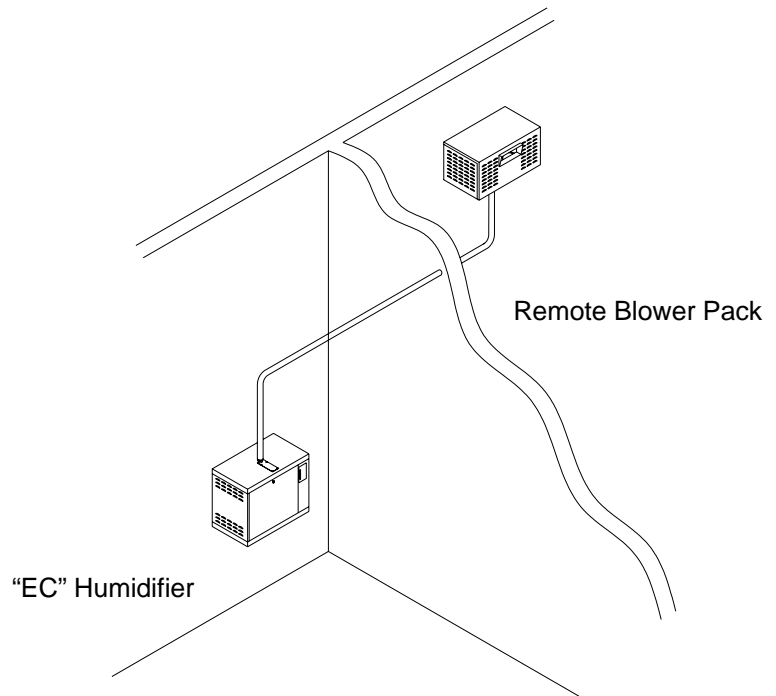

Remote Mounted Blower Pack
Fig. 2



Locating Blower Pack

The distance that visible steam will travel after leaving the Blower Pack is dependent upon the relative humidity in the room and the capacity of the humidifier. If this visible steam comes in contact with any solid object (walls, beams, machinery, etc.) it may form condensate and drip. Refer to Fig. 3 (Fig. 3 is located on page EC-6) and Table 4 for data on visible steam travel. This will aid you in planning the location of the Blower Pack.

Table 4

Visible Steam Rise & Throw		Humidifier Model					
		EC-5	EC-10	EC-15	EC-20	EC-25	EC-35
50% RH	Rise (ft)	1'	2'	3'	4'	5.5'	8'
	Throw (ft)	8'	10'	13'	16'	18'	23'
60% RH	Rise (ft)	2'	3'	4'	5'	6'	8'
	Throw (ft)	13'	14'	16'	18'	20'	25'

Throw is the horizontal distance the visible steam travels from the steam discharge.

Rise is the vertical distance the visible steam travels from the steam discharge.

Objects in the direct line of the visible steam or objects that are cooler than the ambient temperature may accumulate condensation.

Note: Data above based on 70°F room temperature.

296/435 CFM Fan
120/1/60*, 2.17 amps
1/15 HP

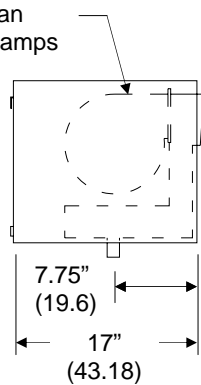

Left Side View

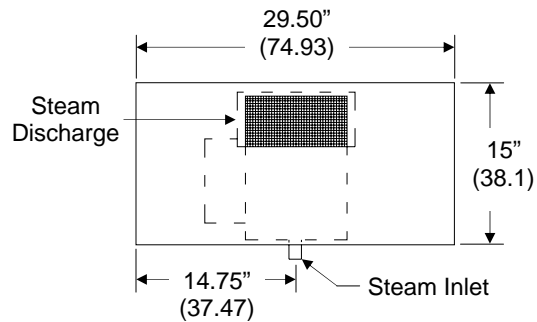

Front View

Optional Blower Pack Dimensions

Fig. 5

Blower Pack weight is 60 lbs (27.2 kg)

* Blower requires a separate 120/1 circuit (by others)



Humidifier

1. The humidifier shall be electrically heated immersion heater type as manufactured by PURE Humidifier Company of Chaska, Minnesota.
2. The humidifier shall be tested and approved by ETL Testing Laboratories, Inc. (ETL# 472940).
3. The humidifier shall have an evaporating reservoir with a gasket-sealed cover that is capable of operating at pressures of at least 19" (48 cm- W.C.) without steam or water leaks. The reservoir shall be made of type 304 stainless steel with welded joints. Reservoir shall be mounted on slide rails for easy removal from cabinet.
4. The reservoir shall be contained within a cabinet that is constructed of 18-gauge steel with a baked enamel finish. The cabinet floor shall be designed as a drain pan with plumbing connections for drain piping.
5. A surface water flusher shall be included to drain away a portion of the water upon each refill cycle. This is to allow mineral deposits produced by earlier evaporation cycles to be removed. Flusher shall be designed for minimal water waste and efficient flushing.
6. The immersion heater(s) shall be incoloy clad and designed for 80 watts per square inch. They shall be attached to the reservoir cover and be easily removed for cleaning or inspection. Expansion and contraction of the heater sheath allows mineral build-up to flake off.
7. A brass body, solenoid operated water fill valve shall be factory mounted on the cover of the humidifier reservoir. The fill valve shall be located to allow a minimum water gap of 1-1/2" (3.81 cm). An inline strainer shall be factory mounted on the fill valve to remove any water-born particulate matter before the humidifier fill valve. The water strainer shall have a removable screen to permit periodic inspection and cleaning.
8. The humidifier shall have a manual reset over-temperature switch, factory installed, on the humidifier reservoir. The temperature switch shall provide humidifier over-temperature protection.
9. A solid state, plug-in type control module shall be factory mounted on the control panel and shall electronically control the automatic refilling, low water cut-off, high water cut-off, manual surface water flushing, and safety switch interlock functions. The module shall include automatic drain functions to drain the reservoir. A cumulative timer shall be field adjustable between 10 to 110 hours of operation. When the system is activated the fill valve will be energized to provide a cool-down tempering of the water prior to draining.

The control module shall incorporate LED lights to indicate safety switch interruption, power, fill, heat ready, and drain. The control module shall control all water level control functions through a tri-probe sensor mounted on the cover of the humidifier reservoir. The Tri-Probe sensor with stainless steel shield shall electrically sense the water level within the reservoir.
10. The electrical compartment shall be isolated and watertight from the reservoir compartment. The electrical compartment shall be accessible by a hinged and key-locked door. The panel shall include a factory wired sub-panel with magnetic contactor, Tri-Probe water level control module, fused control circuit transformer, numbered terminal block, and heater fuse(s). The high voltage wiring shall be shielded to prevent shock hazard. The modulating control voltage shall be field adjustable to match the controlling input signal.
11. The humidifier shall be supplied with a wall-mount channel bracket for easy wall mounting. The bracket shall be load tested to a 600 pound capacity.



Humidifier

Insulation. Unit shall be covered (except top cover) with 3/4" (1.9 cm) thick fiberglass duct insulation. Insulation material shall have aluminum foil facing.

Freeze Protection. A factory installed temperature sensor shall be mounted onto the humidifier reservoir. The system shall maintain the water temperature above freezing.

Blower Pack. Unit shall allow for direct space humidification without the use of ductwork. Unit shall be contained within a cabinet that is constructed of 18-gauge steel with a baked enamel paint finish. Unit shall have a two-speed field adjustable fan. The fan is controlled by a thermostat interlock mounted on the steam distributor, it shall activate the fan before steam is discharged and deactivate the fan after all residual steam has been discharged. The blower shall be designed to mount directly on top of the "EC" humidifier or remote wall mounting.

Injection Tubes

Injection Tube(s) and Flexible Hose. Each unit shall include one or more 10-foot (305 cm) sections of 1-1/2" (3.8 cm) I.D. flexible hose and a 1-1/2" (3.8 cm) O.D. stainless steel injection tube long enough to extend across the duct. Steam ports shall direct steam upward into the airflow. The reservoir cover shall have a matching connection so the flexible hose can be connected with two stainless steel hose clamps. A two-piece duct plate shall be provided to seal the duct opening.

Multiple Injection Tube Assembly. The tube assembly shall be designed for rapid dissipation of steam inside the ductwork. The assembly shall be provided with a supply/condensate header with a drain connection for the removal of the condensate. The tubes shall be mounted with pitch back to the header so that condensate formed within the tubes is removed. Tubes shall have punched orifices designed so that the use of inserts is not required to prevent condensation from escaping the tube. The tubes shall be welded directly to the header or connected with flexible hose cuffs and clamps. The use of o-rings is not allowable. The assembly shall be able to have the header mounted inside or outside the air stream. Supply and condensate piping shall only be on one side of the duct/AHU.

Insty-Pac Tube Assembly. The tube assembly shall be designed for rapid dissipation of steam inside the ductwork. The assembly shall be provided with a supply/condensate header with a drain connection for the removal of the condensate. The tubes shall be mounted level. The tube design shall be a tube-within-a-tube design to minimize condensate loss. Tubes shall have punched orifices designed so that the use of inserts is not required to prevent condensation from escaping the tube. The tubes shall be welded directly to the header, or connected with

flexible hose cuffs and clamps. The use of o-rings is not allowable. The assembly shall be able to have the header mounted inside or outside the air stream. Supply and condensate piping shall only be on one side of the duct/AHU.

Modulating Controls (select one)

Time Cycle Modulation. A TCM controller shall be factory mounted and wired on the control panel and provide modulating control of the humidifier capacity from 0-100%. The heaters shall be time cycle modulated according to the humidistat demand. A modulating wall humidistat (shipped loose) shall be provided with the system.

SCR Controller. A 100% solid state power controller shall be provided on the control panel with a matching modulating wall humidistat (shipped loose). The SCR power controller will modulate the humidifier between 0-100% of its rated capacity according to humidistat demand.

Controls

Auto-Selector. A dual input, single output auto-selector shall be supplied to provide a single modulating output signal to the humidifier control cabinet (TCM or SCR modulating option must be specified). The auto-selector shall allow the use of a modulating wall mount humidistat and modulating duct high-limit humidistat (optional) to control critical variable air volume (VAV) air handling systems. The system shall automatically determine which of the two modulating signals is dominant and slowly reduces the humidifier output capacity, thus preventing over-saturation of the VAV system.

Outdoor Air Temperature Setback. Provides automatic reduction of RH set point to prevent condensation on windows during extreme cold weather.

Seasonal "End of Use" Humidifier Drain. The humidifier will automatically drain the reservoir after a non-use time period which is field adjustable. Upon receiving a call for humidity, the system automatically refills the reservoir and allows the humidifier to operate in "Normal Mode".

INTAC[®] Microprocessor Controller. The controller shall be factory-mounted and wired on the electrical compartment door. The INTAC[®] shall provide 20 character vacuum fluorescent digital display of all functions, high/low humidity deviation alarms, time to service shall be capable of *flash memory downloading* via a RS-232 port to upgrade software with updates. Software updates shall be capable of being provided to customer via e-mail or Internet.